

Translation of the original installation and maintenance instructions

BRIDGE MODULE WITH TOOTHED BELT DRIVE

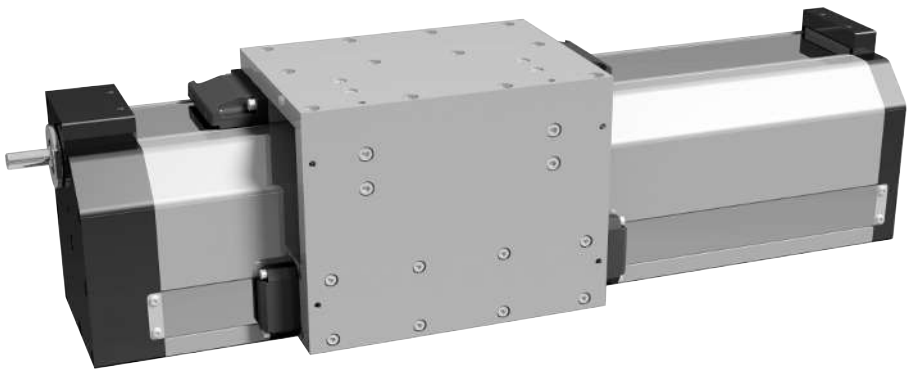

 Read the installation and maintenance instructions before carrying out any work!

Table of contents

1	General information	5
1.1	Information about these assembly instructions.....	5
1.2	Notes on use.....	6
1.3	Structure of the warnings.....	7
1.4	Symbols used.....	9
1.5	Disclaimer.....	10
1.6	Spare parts.....	12
1.7	Warranty conditions.....	12
1.8	Customer service and product monitoring.....	13
1.9	Applicable documents.....	13
2	Safety	14
2.1	Introduction.....	14
2.2	Intended use.....	14
2.3	Foreseeable misuse.....	14
2.4	Responsibility of the operator.....	15
2.5	Personnel requirements.....	16
2.5.1	General personnel requirements.....	16
2.5.2	Qualifications.....	16
2.5.3	Unauthorized personnel.....	16
2.6	Personal protective equipment.....	16
2.7	Residual risks.....	18
2.7.1	Note.....	18
2.7.2	Mechanical hazards.....	18
2.7.3	Hazards at the operating site.....	18
2.7.4	Hazards due to noise.....	19
2.8	Environmental protection.....	19
3	Structure and function	20
3.1	Product overview.....	20
3.2	Product description.....	21
3.3	Type plate.....	22
4	Transport	23
4.1	Safety.....	23
4.2	Transport by forklift.....	24
4.3	Transport with the crane.....	24
4.4	Transport inspection and scope of delivery.....	25
4.5	Storage.....	26
5	Assembly	27
5.1	Safety.....	27
5.2	Delivery configurations.....	28

5.3	Preparation for motor mounting	31
5.4	Permissible deflection with toothed belt drive	33
5.5	Attaching the bridge module	34
5.5.1	General information	34
5.5.2	Attaching the bridge module using clamping flanges	34
5.5.3	Attaching the bridge module using sliding blocks	36
5.6	Assembling limit switches	37
5.6.1	Limit switch assembly	37
5.6.2	Overview of limit switch/reference switch installation	37
5.6.3	Position of the limit switches	39
5.6.4	Limit switch mounting	41
5.7	Installing the motor and gearbox	42
5.7.1	General information	42
5.7.2	Straight, with toothed belt drive	42
5.7.3	Gearbox mounting HPG...x1 and HPG...x2	44
6	Operation	45
6.1	Safety	45
6.2	Operating conditions	46
7	Maintenance	47
7.1	Safety	47
7.2	Repairs	48
7.3	Maintenance intervals	48
7.3.1	Notes	48
7.3.2	Maintenance schedule	49
7.4	Maintenance work	49
7.4.1	Checking the bridge module for externally visible damage	49
7.4.2	Lubricating bridge modules	50
7.4.3	Tensioning the toothed belt	53
7.5	Measures after completing the maintenance work	54
8	Faults	55
8.1	Safety	55
8.2	Behavior if a fault represents a hazard	55
8.3	Possible faults	56
8.4	Measures after completing the troubleshooting work	56
9	Disassembly and disposal	57
9.1	Safety	57
9.2	Decommissioning and disassembly	57
9.3	Disposal	58
10	Technical data	59
10.1	General technical data	59
10.2	Technical data for toothed belt drive	60

10.3	Tightening torques for screws.....	60
10.4	Permissible speeds.....	61
10.5	Bridge module: technical data.....	62
10.5.1	Exploded view and parts list for bridge module BM4...NZ...N	62
10.5.2	Exploded view and parts list for bridge module BM4...BZ...N.....	63
10.5.3	Exploded view and parts list for bridge module BM4...NZ...L/R	64
10.5.4	Exploded view and parts list for bridge module BM4...BZ...L/R.....	65
10.5.5	Linear module dimensions BM4...NZ...N	66
10.5.6	Linear module dimensions BM4...BZ...N	67
10.5.7	Linear module dimensions BM4...NZ...L/R	68
10.5.8	Linear module dimensions BM4...BZ...L/R	69
11	Declaration of Incorporation.....	70
	Keyword index	73

This document is protected by copyright and is intended for internal use only. Any provision of the document to third parties, any mode or form of reproduction – including excerpts –, any use and/or communication of the content, as well as translation into other languages, is not permitted without the prior consent of the manufacturer unless it is exclusively for internal use.

1 General information

1.1 Information about these assembly instructions

Using the assembly instructions

These assembly instructions allow you to work safely and efficiently with the bridge module throughout all phases of the bridge module's service life. All warnings and instructions in these assembly instructions must be observed in order to ensure safe working conditions.

Reading obligation

The operating/maintenance personnel are required to carefully read and understand these assembly instructions before starting any work.

Storage location

The assembly instructions are an integral part of the bridge module and must be kept readily available to the relevant personnel in the immediate vicinity of the bridge module.

Resale

If the positioning unit is resold to a third party, these assembly instructions must also be included.

Applicable documents, regulations and provisions

In addition to these assembly instructions, the instructions, notes and signs on the bridge module in the annex also apply. Attach any notes on technical changes to these assembly instructions. In addition, the local accident prevention regulations and general safety requirements for the area where the bridge module is used apply.

Figures in these assembly instructions

Figures contained in these assembly instructions are provided for basic understanding and may vary from the actual version of the bridge module.

Loss of the assembly instructions

If the assembly instructions are lost, request a replacement set immediately. Contact details Legal notice (See reverse side) .

1.2 Notes on use

Instructions and steps

Steps to be performed by the operating personnel are shown consecutively. The sequence of steps must be observed.

Example:

a) Step 1

Lists

Lists without a mandatory sequence of steps are shown as a list preceded by a bullet point.

Example:

- Item 1
 - Item 1, subitem A
- Item 2

Lists with a mandatory sequence of steps are shown as a list preceded by numbers.

Example:

1. First
2. Second

References to chapters/pages

References to specific chapters in which procedures and instructions are described are displayed as active links.

Example: see chapter *Information about these assembly instructions* [[▶ 5](#)].

Illustrations

All figures and drawings in these assembly instructions are intended for general illustration purposes. They may vary from the actual design of the bridge module.

1.3 Structure of the warnings

The warnings used in these assembly instructions are introduced by signal words that indicate the extent of the danger.

The warning symbol additionally indicates the type of hazard.

The following warnings are used in these assembly instructions:

Danger level: Danger to life



⚠ DANGER

Danger to life!

Consequences in case of non-compliance...

▶ Notes on prevention

A warning with this danger level indicates an imminent dangerous situation.

If the dangerous situation is not avoided, it will result in death or serious injury.

Follow the instructions in this warning to avoid the risk of death or serious personal injuries.

Danger level: Risk of injury**⚠WARNING****Risk of injury!**

Consequences in case of non-compliance...

- ▶ Notes on prevention

A warning with this danger level indicates a potentially dangerous situation.

If the dangerous situation is not avoided, it may result in death or serious injury.

Follow the instructions in this warning to avoid the possible risk of death or serious personal injuries.

Danger level: Personal injury**⚠CAUTION****Personal injury due to...**

Consequences in case of non-compliance...

- ▶ Notes on prevention

A warning with this danger level indicates a potentially dangerous situation.

If the dangerous situation is not avoided, it may result in minor or moderate injuries.

Follow the instructions in this warning to avoid personal injuries.

Danger level: Property damage**NOTICE****Property damage due to...**

Consequences in case of non-compliance...

- ▶ Notes on prevention

A warning with this danger level indicates possible material damage.

If the situation is not avoided, material damage may occur.

Follow the instructions in this warning to avoid material damage.

Note on working safely



SAFETY INSTRUCTIONS
<p>Working safely during...!</p> <p>Carry out all work in compliance with the following safety instructions:</p> <ul style="list-style-type: none"> ▶ Notes on working safely

This note contains important information and instructions for working safely during the following steps.

Follow the instructions in this note to avoid accidents and injuries.

Note regarding useful information



NOTE
<p>Note text...</p> <p>Consequences</p>

A note indicates additional information that is important for further processing or simplifies the described step.





1.4 Symbols used

Warnings in these assembly instructions are also marked with warning symbols.

Warning symbols

The following warning symbols are used in these assembly instructions:

Symbol	Meaning
	General warning message
	Warning of electrical voltage

Symbol	Meaning
	Warning of hand injuries
	Warning of heavy loads
	Warning of suspended load
	Warning of environmental pollution

1.5 Disclaimer

Information in these assembly instructions

The information and warnings contained in these assembly instructions have been compiled taking into consideration the applicable standards, guidelines and regulations, the state of the art as well as our many years of experience. The scope of delivery or the design of the bridge module may vary from the descriptions and figures provided here due to optional order items, the production of customized designs or the latest technical changes.

Obligations

In addition to the contractually agreed obligations, the manufacturer's General Terms and Conditions of Business and Delivery apply. They are subject to the laws in force at the time when the contract is concluded.

Technical changes

The date of issue of these assembly instructions applies. We reserve the right to make technical changes to the bridge module within the scope of further development in order to improve its performance features and safety.

Disclaimer in case of non-compliance

The manufacturer is not liable for damage and accidents resulting from the following:

- Non-intended use (*Intended use* [► 14]) of the bridge module
- Non-compliance with the information and instructions in these assembly instructions
- Work performed on or with the bridge module by unqualified or unauthorized personnel
- Installation of non-original spare parts
- Unauthorized modifications without written acceptance by the manufacturer

1.6 Spare parts

Spare parts must be ordered from the manufacturer. See the reverse side for contact details.



⚠ CAUTION

Incorrect or faulty spare parts.

Risk of injury, risk of damage, malfunctions or total failure!

- ▶ Only use original spare parts from the manufacturer or spare parts approved by the manufacturer.
- ▶ If in doubt, contact the manufacturer.



NOTE

If non-approved spare parts are used, all warranty, service, compensation and/or liability claims against the manufacturer or its agents, dealers and representatives will be invalidated.

For all requests for spare parts or when ordering spare parts, always provide the complete data on the type plate.

1.7 Warranty conditions

Location

The warranty conditions are included in the purchase contract and the manufacturer's General Terms and Conditions.

Basic information

The manufacturer or sales partner will make the final decision on a warranty claim after all defective parts have been returned or possibly after an on-site inspection. The replacement of defective parts does not extend the warranty period for the bridge module. In case of modifications or significant repairs carried out by the operator or third parties without the written consent of the manufacturer or sales partner, the warranty claim will be completely invalidated.

1.8 Customer service and product monitoring

Customer service

For problems and questions that cannot be solved using these assembly instructions and for technical information, please contact our customer service or sales partner; contact details (See reverse side) .

Product monitoring

We aim to continuously improve our products and are also interested in any experience gathered when using the bridge module.

We are happy to receive information about problems with the bridge module, faults during operation and errors that occur.

Always notify the manufacturer in the event of actual or potential accidents.

1.9 Applicable documents

In addition to the information contained in these assembly instructions, the information contained in the following sources of information, in particular the safety instructions, must also be taken into consideration:

- Information on the type plate of the bridge module
- Instructions for the assemblies used
- Instructions of the operator
- Safety data sheets of auxiliary and operating materials
- Local accident prevention regulations and regional regulations at the operating site of the bridge module
- Data sheets of installed components

2 Safety

2.1 Introduction

This section provides an overview of all the important safety aspects for ensuring optimum protection of personnel and for safe and smooth operation.

Failure to observe the instructions and warnings in these assembly instructions can result in serious hazards.

Only those risks that have been determined based on a risk assessment can be considered in these assembly instructions. Risks that result from work conditions, the place of deployment and interfaces to foreign components must be determined and warnings must be supplemented accordingly.

2.2 Intended use

The bridge module is solely intended for use in industrial applications.

The bridge module is solely intended for installation in machines and is used to move, precisely position and transport light to medium loads.

The permissible values specified in the "*Technical data* [▶ 59]" chapter must be observed.

Any other use or use that goes beyond this is considered improper use.

2.3 Foreseeable misuse

Any use for a purpose other than the one specified in the *Intended use* [▶ 14] chapter is considered improper use.

Any use of the bridge module that goes beyond and/or deviates from the intended use can result in dangerous situations.

The risk of improper use or misuse is borne solely by the operating company.

Misuse occurs, for example, when

- The bridge module is operated outside the limits specified in *Technical data* [▶ 59].
- Modifications are made to the bridge module.
- Safety devices are disabled.
- The bridge module is used in an explosion-protected area.

2.4 Responsibility of the operator

Basic information

The owner of the bridge module is generally subject to the legal requirements concerning occupational safety, since the bridge module is intended for use in the commercial sector. In addition to the warnings in these assembly instructions, the safety, accident prevention and environmental protection regulations applicable to the area in which the bridge module is used must therefore also be observed.

Risk assessment

The operating company must keep itself informed of the applicable health and safety regulations and carry out a risk assessment to determine any additional hazards arising from the specific working conditions at the place where the bridge module is used.

Instructions

The operator must issue, implement, and document operating instructions based on the results of the risk assessment at the workplace.

During the entire time the bridge module is in use, the operating company is responsible for ensuring that the instructions it issues comply with the current legal requirements.

Responsibilities

The operating company must regulate the responsibilities for work on or with the bridge module and designate a person responsible for its safe operation and for coordinating all related activities.

Information flow

The operating company must ensure that all personnel working on or with the bridge module have read and understood these assembly instructions and other instructions. In addition, the operator must train the relevant personnel at regular intervals and inform them about the potential dangers.

Personal protective equipment

The operator must provide the personnel with the required personal protective equipment.

Safety requirements

If necessary, the operating company must ensure that the machine in which this bridge module is to be installed, or of which it is a component, complies with the basic safety requirements and provisions of all relevant directives before commissioning.

Perfect working order

In order to keep the bridge module in perfect working order at all times, the operating company must ensure that the maintenance intervals specified in these assembly instructions are observed.

2.5 Personnel requirements

2.5.1 General personnel requirements

Only persons who reliably perform their work and whose ability to react is not influenced, e.g., by drugs, alcohol or medication, are permitted to work on or with the machine.

When selecting such personnel, the job-specific age requirements applicable at the location where the bridge module is used must be observed.

2.5.2 Qualifications

Improper handling due to insufficient qualification can result in significant injuries.

- Have all activities performed out only by qualified personnel.
- Keep unqualified personnel away from the danger areas.

The following qualifications are specified in the assembly instructions for various areas of activity:

Qualified specialist personnel

Qualified specialist personnel can carry out the assigned work and independently identify and avoid potential hazards due to their specialist training, knowledge and experience as well as knowledge of the relevant standards and regulations.

Manufacturer (Service center)

Some work must only be carried out by the manufacturer's qualified personnel. Other personnel are not authorized to perform this work. Contact the manufacturer's service department to carry out the necessary work (see the Legal notice on the reverse side).

Instructed person (operator)

An instructed person has been informed by the operator about the tasks assigned to them and about possible dangers in the event of improper behavior.

2.5.3 Unauthorized personnel

Unauthorized personnel who do not meet the requirements described here are not aware of the dangers in the work area.

- Keep unauthorized personnel away from the work area.
- In case of doubt, address the personnel and direct them away from the work area.
- Stop working as long as unauthorized personnel are in the work area.

2.6 Personal protective equipment

Some work requires personnel to wear personal protective equipment to minimize health hazards. In addition to the personal protective equipment specified in these assembly instructions, the instructions posted in the work area must be observed. The following personal protective equipment must be worn depending on the work to be performed:

Symbols	Meaning
	<p>Suitable protective clothing is close-fitting work clothing with low tear resistance, tight sleeves and no parts that stick out. It is primarily used to protect against being caught by moving machine parts. Do not wear rings, chains or other jewelry.</p>
	<p>Safety shoes are used to protect against heavy falling parts and slipping on slippery surfaces.</p>
	<p>Protective gloves are used to protect hands from friction, abrasions, punctures or deeper injuries, as well as from contact with hot surfaces.</p>
	<p>Hearing protection is used to protect hearing in case of potentially harmful noise levels.</p>
	<p>Safety goggles are used to protect the eyes from flying small parts, dust or compressed air.</p>



NOTE

External visitors or employees from other departments must also wear personal protective equipment when entering the work area.

2.7 Residual risks

2.7.1 Note

The following section identifies residual risks that have been identified based on a risk assessment.



SAFETY INSTRUCTIONS

Note on working safely!

Failure to observe the safety instructions, warnings and working instructions provided in these operating instructions may result in significant hazards.

- ▶ Always observe the safety instructions, warnings and handling instructions!
- ▶ Also observe the safety instructions provided in the other applicable documents!

2.7.2 Mechanical hazards

Moving bridge module parts

Risk of injury between moving bridge module parts!

Parts of the body can get trapped or crushed between moving bridge module parts.

- Do not reach into moving bridge module parts during operation. Do not handle moving bridge module parts.
- Do not open covers during operation.
- Observe the lag time: make sure that no parts are moving before opening the covers.
- Wear close-fitting clothing and tie up long hair.

2.7.3 Hazards at the operating site

Operating the bridge modules at an unsuitable or insufficiently equipped operating site poses various hazards!

Safety deficiencies caused by work performed incorrectly due to inadequate lighting:

- Make sure that there is sufficient lighting at the workplace.
- Have defective lamps replaced immediately.

Sharp edges, corners and materials with sharp edges can cause abrasions and cuts on the skin::

- Exercise caution when working near sharp edges and corners and when handling materials with sharp edges.
- In case of doubt, wear protective gloves.

Contamination and objects lying around create sources of slipping and tripping:

- Always keep the work area clean.
- Remove items that are no longer needed.

- Mark tripping hazards with yellow and black marking tape.
- Remove any spilled liquids immediately.

Danger of short circuits due to unsuitable application area:

- Only operate the linear bridge indoors.
- Protect the bridge module from moisture.

2.7.4 Hazards due to noise

The bridge module itself does not emit any hazardous noise emissions. However, during operation in combination with the connected machines, noise levels may occur that could potentially lead to tinnitus or hearing loss.

- The emissions must be measured by the operator after the entire system has been assembled:
 - If the measured noise level is ≥ 80 dB(A), the operating company must make hearing protection available.
 - If the measured noise level is ≥ 85 dB(A), the operating company must make the use of hearing protection mandatory.

2.8 Environmental protection

Danger to the environment due to the improper handling of environmentally hazardous substances, especially their incorrect disposal:

- Always follow the instructions provided below.
- If environmentally hazardous substances are accidentally released into the environment, take appropriate measures immediately. In case of doubt, notify the responsible authority of the damage.
- Collect, transport and store environmentally hazardous substances in suitable containers only.

The following environmentally hazardous substances are used:

Lubricants

Lubricants such as greases and oils contain toxic substances. They must not be released into the . They must be disposed of by a specialist disposal company in accordance with local applicable regulations.

Machine parts

Replaced machine parts may, for example, be contaminated by grease and oil and therefore contain toxic substances. They must not be released into the environment. They must be disposed of by a specialist disposal company in accordance with local applicable regulations.

3 Structure and function

3.1 Product overview

The following exploded view shows a bridge module in its maximum configuration. The actual scope of delivery may vary from this version.

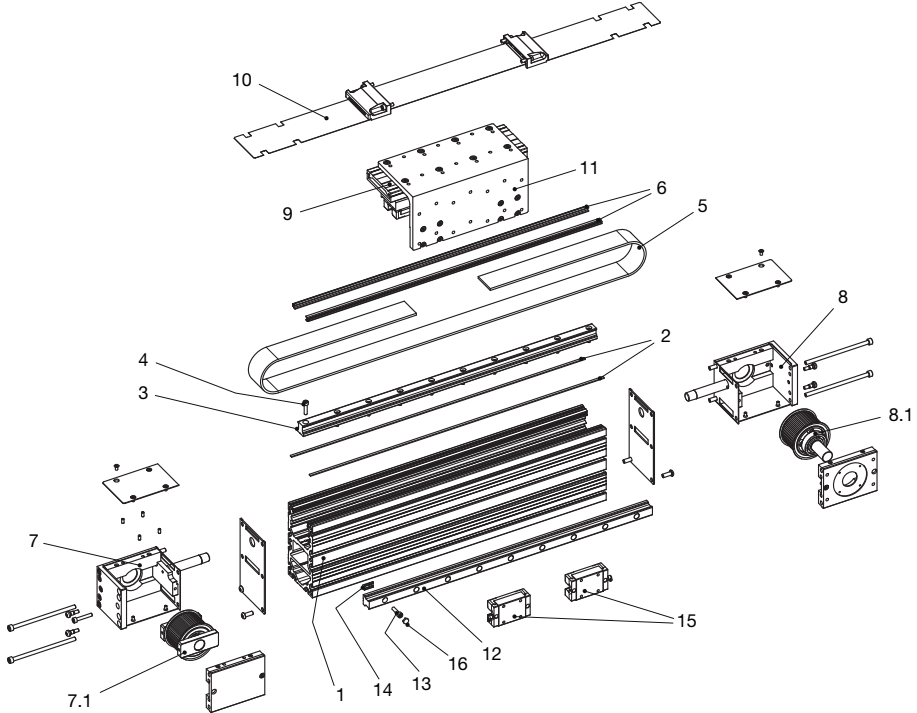

- | | | | |
|-----|----------------------------|-----|---------------------------------|
| 1 | Casing profile | 8.1 | Drive sprocket kit |
| 2 | Magnetic tape | 9 | Carriage |
| 3 | Linear rail | 10 | Complete cover strip |
| 4 | Screw for linear rail | 11 | Angle bracket for support rail |
| 5 | Toothed belt | 12 | Support rail |
| 6 | Toothed belt guide profile | 13 | Screw for support rail |
| 7 | Deflection housing | 14 | T-slot nut for support rail |
| 7.1 | Deflection sprocket kit | 15 | Guide carriage for support rail |
| 8 | Drive housing | 16 | Cover cap for support rail |

3.2 Product description

Bridge modules with toothed belt drives are precise, ready-to-install, modular linear carriages with drives. Sealed guide elements are used in all sizes. Linear guides and drives are protected against external influences, such as contamination and chips, etc. by means of steel cover strips and the toothed belt drive. The base and side profiles are made of aluminum alloy and are manufactured via an extrusion process. Additional externally mounted limit switches, in combination with motors and a control system, ensure the correct positioning of the carriage and protect against overrun. The selected design results in very high performance with highly compact dimensions.

The following load ratings are achieved:

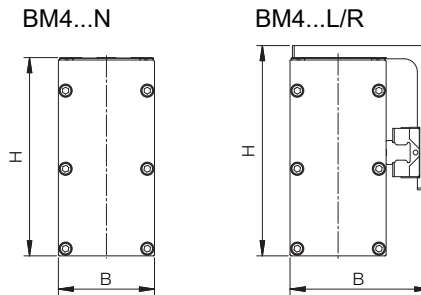

Bridge module Type	Dimensions W x H [mm]	Load ratings	
		C ₀ [kN]	C [kN]
BM4...N	80 x 165	59.9	34.2
BM4...L/R	117 x 174	119.9	68.4

3.3 Type plate

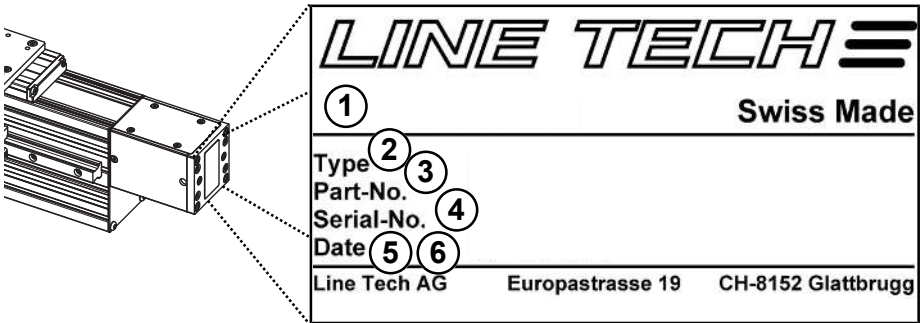

The following information is included on the type plate and makes it easy to identify the module:

- Description (1)
- Type designation (2)
- Part number (3)
- Serial number (4)
- Manufacturing date; calendar week/year (5)
- Repair date (6; if available)



NOTE

If problems occur with the module, provide the manufacturer or sales partner with the information on the type plate.

4 Transport

4.1 Safety



SAFETY INSTRUCTIONS

Working safely while transporting the bridge module!

Carry out all work in compliance with the following safety instructions:

- ▶ Comply with the provisions listed in the *Safety* [▶ 14] chapter for all work performed on/with the bridge module.
- ▶ Observe the instructions and personnel requirements as per the *Personnel requirements* [▶ 16] chapter.
- ▶ Provide suitable forklift trucks or lifting gear for transportation.
- ▶ Wear personal protective equipment (safety shoes, protective gloves and hard hat).



NOTICE

Property damage due to improper transportation!

Improper transportation may result in property damage.

- ▶ Do not expose the parts to be transported to hard shocks during transportation.
- ▶ Make sure there is sufficient free space during transport.
- ▶ Always provide support for bridge modules longer than 700 mm during transportation.
- ▶ Use caution when lifting and setting down the machine.

4.2 Transport by forklift

Conditions for transportation

Packages that are attached to pallets can be transported with a forklift under the following conditions:

- The forklift must be designed for the weight of the transport items.
- The item to be transported must be securely fastened to the pallet.
- The forklift driver is authorized to do this.

Lifting packages

- a) Drive the forklift with the tines between or under the pallet's beams.
- b) Drive the tines in far enough that they protrude on the opposite side.
- c) Make sure that the pallet cannot tip if the center of gravity is eccentric. Observe the special information about the center of gravity on the packages.
- d) Lift the pallet with the transport unit and begin the transport operation.

4.3 Transport with the crane



WARNING

Danger to life from suspended loads!

Danger from falling or uncontrolled swinging parts.

- ▶ Never stand under suspended loads.
- ▶ Do not attach lifting gear to protruding module parts or to eyelets on attached components. Ensure that the slings are securely fastened.
- ▶ Only use approved lifting gear and slings with sufficient load capacity.
- ▶ Transport may only be carried out by personnel trained for this purpose.

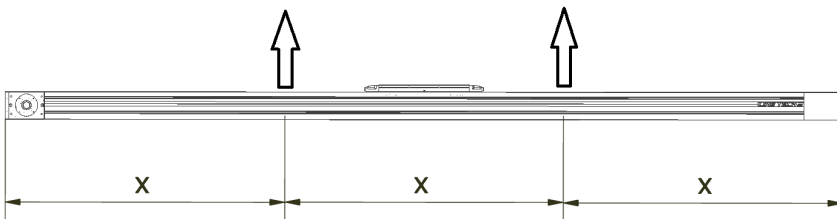

Conditions for transportation

The bridge modules or packages that are secured to pallets or packed in crates can be lifted and moved with a crane (for bridge modules or packages that exceed a length of 9 meters, consult the manufacturer).

Ensure that

- the slings are designed for the weight to be lifted.
- the crane operator is authorized to do so.

Lifting bridge modules or packages

Lift bridge module or packages as follows:

- a) Ensure that the carriage is positioned approximately in the center.
- b) Attach bridge modules or packages.
- c) Attach two lifting straps at equal distances ($\frac{1}{3}$ / $\frac{1}{3}$ / $\frac{1}{3}$) and lift vertically.
- d) Do not choose an angle of attack that is too flat.
- e) Ensure that ropes and straps, etc. are not twisted and that the bridge module or packages are securely fastened.
- f) Lift the bridge module or packages and begin the transport operation.

4.4 Transport inspection and scope of delivery

Transport inspection

Check that the delivery is complete and that there is no transport damage immediately upon receipt.

If there is any visible external transport damage, proceed as follows:

- Do not accept the delivery or only accept it with reservations.
- Record the extent of the damage on the transport documents or on the carrier's delivery document.
- Submit a complaint.



NOTE

Report any defect as soon as it is detected. Claims for damages can only be made within the valid complaint periods.

Scope of supply

Refer to the delivery document for the scope of delivery. The scope of delivery of the product includes:

- Bridge module as specified in the order confirmation
- Assembly and maintenance instructions
- Additional and special accessories according to the order

4.5 Storage



NOTICE

Property damage due to improper storage!

Improper storage may result in property damage.

- ▶ Always store the bridge module/bridge module parts in compliance with the following conditions.
- ▶ Use caution when lifting and setting down the machine.

If the bridge module is not used for more than two months or is stored before installation, observe the following conditions:

- Make sure that the bridge module is clean. Clean the bridge module if necessary.
- Do not store outdoors.
- Store in a dry location that is free of dust.
- Do not expose to aggressive media.
- Protect from sunlight.
- Avoid mechanical vibrations.
- Store the bridge module in a box that is well-padded.

5 Assembly

5.1 Safety



SAFETY INSTRUCTIONS

Working safely while assembling the bridge module!

Carry out all work in compliance with the following safety instructions:

- ▶ Comply with the provisions listed in the *Safety* [▶ 14]chapter for all work performed on/with the bridge module.
- ▶ All installation work must only be carried out by specially trained personnel (see the *Personnel requirements* [▶ 16] chapter).
- ▶ Work on electrical systems must only be carried out by qualified personnel (see the *Qualifications* [▶ 16] chapter).
- ▶ Wear protective equipment in accordance with local accident prevention regulations for all assembly work.
- ▶ Make sure that there is sufficient space for assembly before starting work.
- ▶ Make sure that the assembly area is tidy and clean! Components and tools that are loosely stacked on top of each other or lying around create a risk of accidents.
- ▶ If components have been removed or adjusted, ensure correct assembly, reinstall all fastening elements and observe the screw tightening torques.
- ▶ Do not stand under suspended loads.
- ▶ Observe the relevant environmental protection instructions. If environmentally hazardous substances are accidentally released into the environment, take appropriate measures immediately. In case of doubt, notify the responsible local authority of the damage.

5.2 Delivery configurations

LINE TECH bridge modules with toothed belt drives are available in various configurations and with different pre-installed motor attachments.

The following delivery configurations are possible:

Delivery configuration 11 - Free shaft end on right:

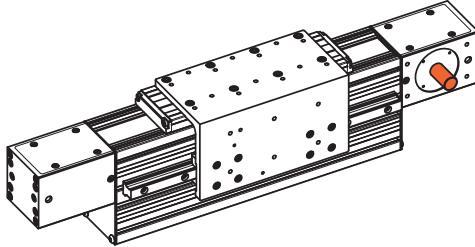

Delivery configuration 12 - Free shaft end on left:

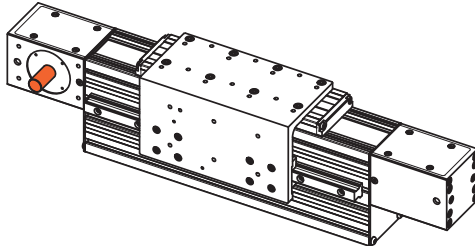

Delivery configuration 13 - Shaft end on right with coupling and intermediate flange:

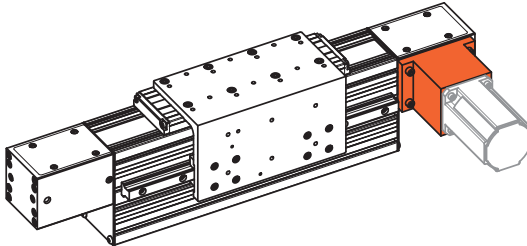

Delivery configuration 14 - Shaft end on left with coupling and intermediate flange:

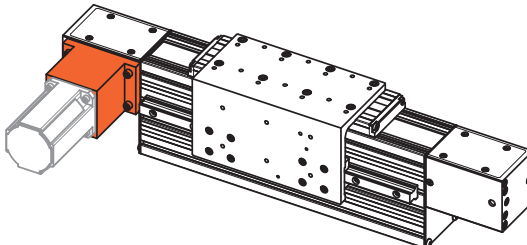

Delivery configuration 00 - without drive:

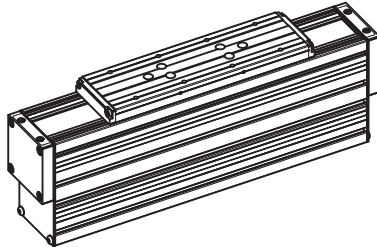

Delivery configuration 17 - Free shaft end on both sides:

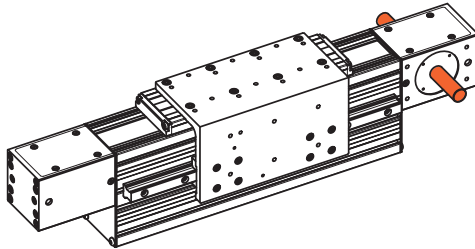

Delivery configuration 18 - Shaft end on both sides, with coupling and intermediate flange on right:

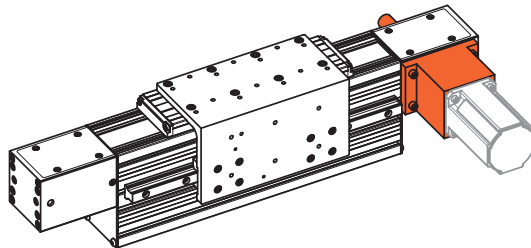

Delivery configuration 19 - Shaft end on both sides, with coupling and intermediate flange on left:

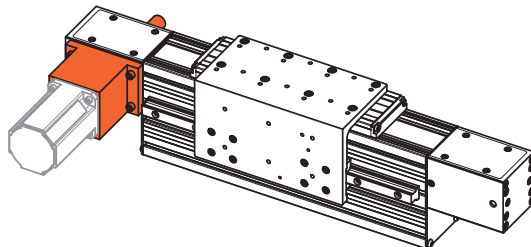

Delivery configuration 25 - Shaft end on right with gearbox attachment:

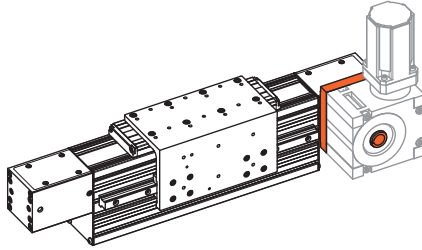

Delivery configuration 26 - Shaft end on left with gearbox attachment:

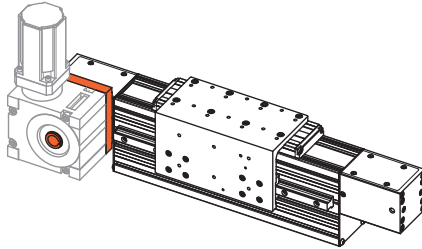

Delivery configuration 27 - Shaft end on both sides with gearbox attachment:

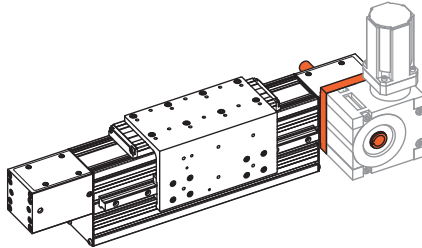

Delivery configuration 28 - Shaft end on both sides, with gearbox attachment on left:

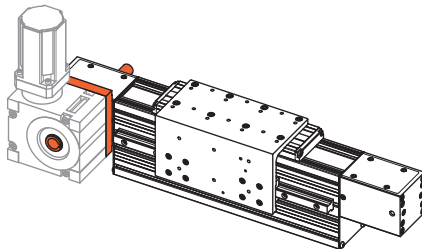

5.3 Preparation for motor mounting

For delivery configurations 25 to 28 (see chapter *Delivery configurations* [▶ 28]), the gearbox mounting plate can be mounted in different ways depending on the desired gearbox assembly or motor alignment. The following variants are possible.

Gearbox assembly D - gearbox to the rear and top:

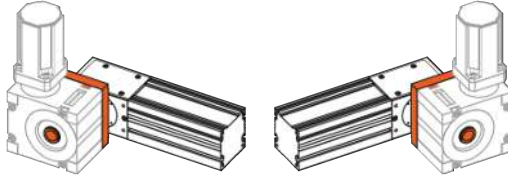

Gearbox assembly E - gearbox to the front and top:

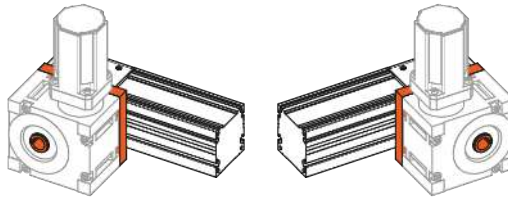

Gearbox assembly F - gearbox to the rear and bottom:

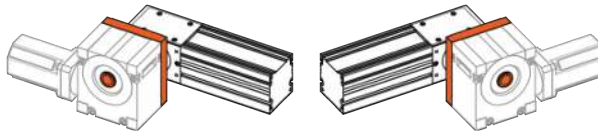

Gearbox assembly G - gearbox to the rear and top:

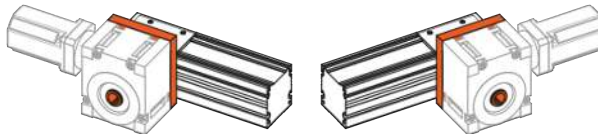

Gearbox assembly H - gearbox to the front and top:

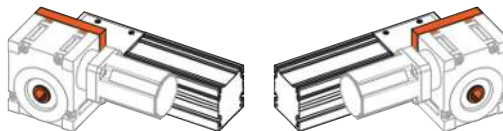

Gearbox assembly K - gearbox to the front and bottom:

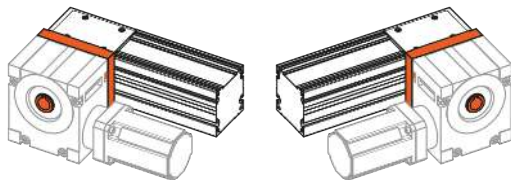

Gearbox assembly L - gearbox to the front and bottom:

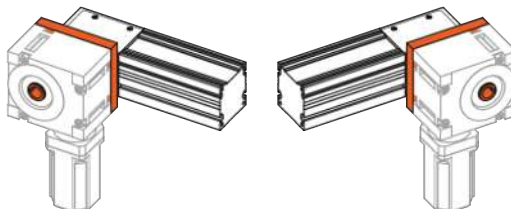

Gearbox assembly M - gearbox to the rear and bottom:

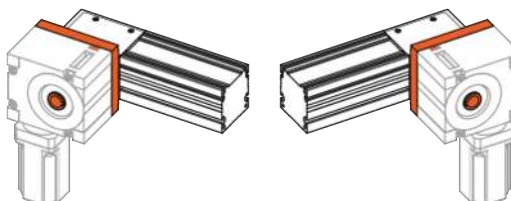

5.4 Permissible deflection with toothed belt drive

Bridge modules can be installed as cantilevered structures. However, deflection must be taken into consideration, since this limits the possible load.

If the maximum permissible deflection is exceeded, the bridge modules must be additionally supported.

The maximum permissible deflection is limited by the maximum deflection angle of 5°. If this value is exceeded without support, it will affect the module's service life.

If there are increased requirements for system accuracy, we recommend supporting the bridge modules along their entire length.

The following diagrams apply to:

- fixed clamping (40 – 50 mm per side)
- 3 – 4 screws per side
- Fixed substructure
- Horizontal installation position

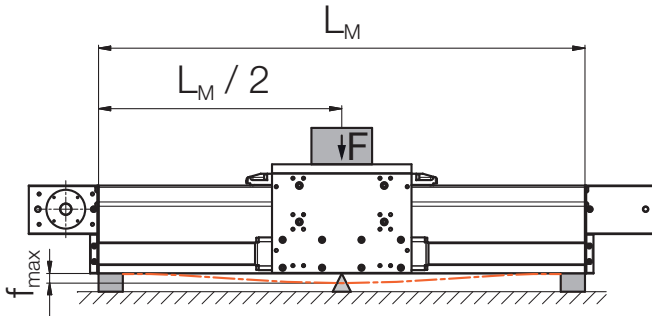

BM4...N or BM4...L/R... with toothed belt drive

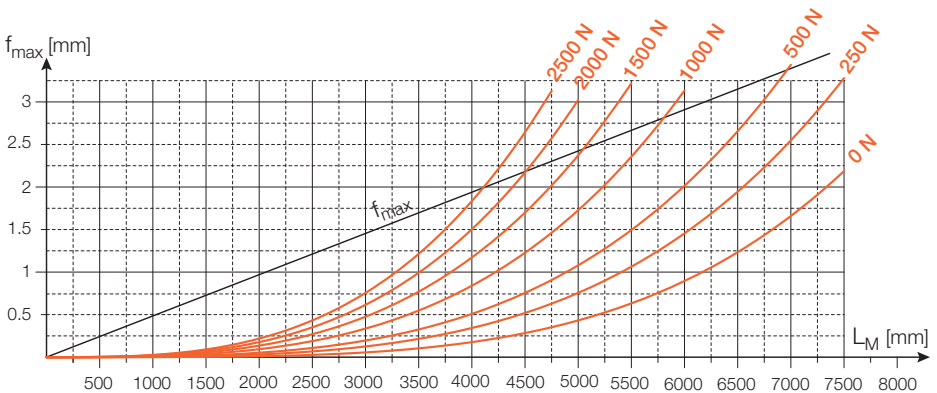

5.5 Attaching the bridge module

5.5.1 General information

Attach the bridge modules using clamping flanges or sliding blocks.



NOTICE

Property damage due to improper fastening!

If end plates are used as load-bearing elements, the bridge module may be damaged.

- ▶ Only fasten or support bridge modules on the base profile and not on the end plates.

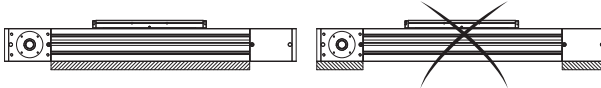

5.5.2 Attaching the bridge module using clamping flanges

Overview

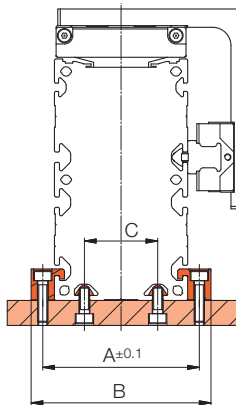

Nominal size	Dimensions [mm]		
	A	B	C
BM4...	94	108	44



NOTE

If the V/W design is selected, the bridge module cannot be attached using clamp flanges.

Assembly options

Use the following number of clamping flanges:

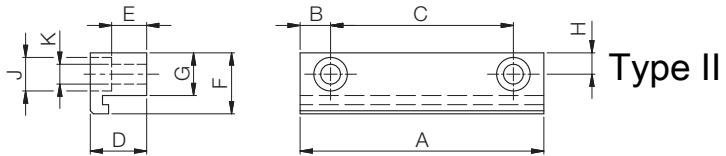

– 4 clamping flanges per meter and side, type II

The clamps can be ordered from LINE TECH AG according to the following table.

Nominal size	Dimensions [mm]											Weight [kg]	Art. No.
	Type	A	B	C	D	E	F	G	H	J	K		
BM4...	II	80	10	20	17.8	10.8	20	14	7	Ø 11	Ø 6.5	0.148	M-40357

Assembly

- a) Attach the bridge modules using clamping flanges.
- b) Secure screws with Loctite.
- c) Observe the tightening torques (see *Tightening torques for screws* [p. 60]).

5.5.3 Attaching the bridge module using sliding blocks

Usage

Sliding blocks with the corresponding groove width can be used to fasten attachments and extensions to the base profile.

Sliding block types

The type of sliding block to be used depends on the groove width:

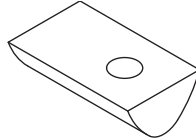
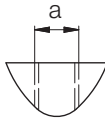

Dimensions [mm]		The material
Groove width	a (thread)	
5	M3/M4/M5	Steel/stainless steel
6	M4/M5/M6	Steel/stainless steel

When ordering sliding blocks, please specify the size, material, and connection thread (e.g., NS6 St M5).

5.6 Assembling limit switches

5.6.1 Limit switch assembly

The limit switches are supplied as standard without a connector box with 2-meter-long cables (order code N); a plug box with pre-wired cables is available as an option (order code S).

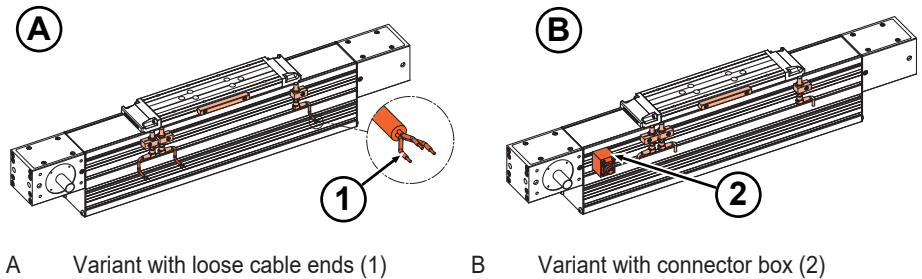

NOTE

Limit switches, mating connectors, and cables are not included in the scope of delivery. They can be purchased ready-made from LINE TECH AG.

5.6.2 Overview of limit switch/reference switch installation

Function

The limit switches are required in combination with a control unit to limit the stroke (to prevent the carriage from overrunning) and determine a reference point for setting the zero point.

The positive and negative limit switches are preset at the factory to a nominal stroke of 0 to +5 mm.

The following inductive limit switches are used as standard:

- PNP normally closed (PNP NC)
- Power supply: 10...30 V DC
- Current consumption without load: < 10 mA
- Load max. 200 mA

The following limit switches are also available on request:

- PNP normally open (PNP NO)
- NPN normally closed (NPN NC)
- NPN normally open (NPN NO)
- Reed switches
- Mechanical switches

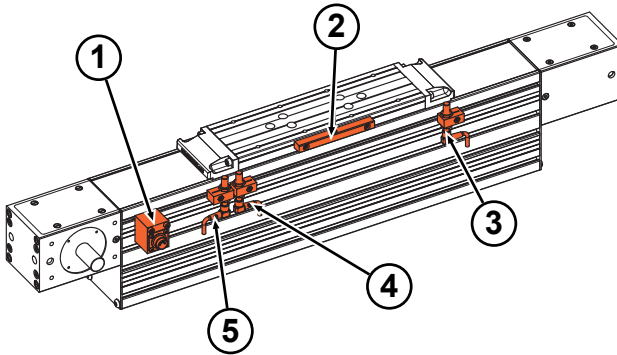
Overview

- | | | | |
|---|---------------------------|---|------------------|
| 1 | Connector box | 2 | Switching lug |
| 3 | Positive limit switch (+) | 4 | Reference switch |
| 5 | Negative limit switch (-) | | |

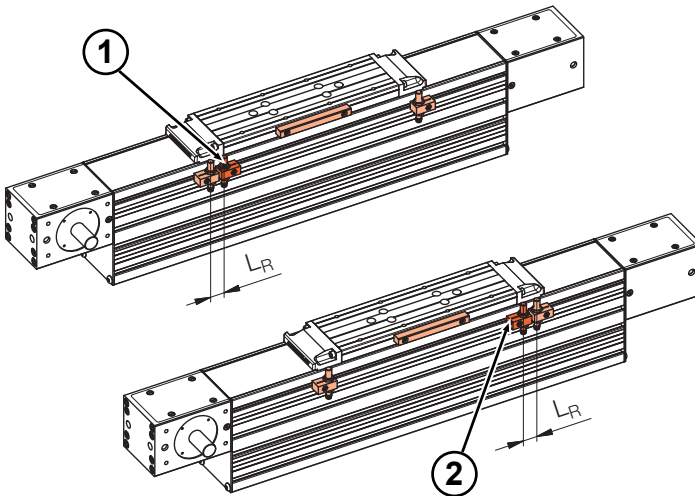
Position reference switch

- | | | | |
|---|--|---|---------------------------------------|
| 1 | Reference switch at front (motor side) | 2 | Reference switch at rear (motor side) |
|---|--|---|---------------------------------------|

Position reference switch (L_R); $L_R = 20$ mm

5.6.3 Position of the limit switches

Position

Refer to the following figure for the position of the limit switches:

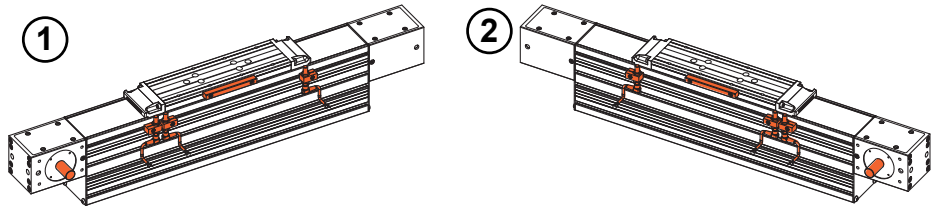

1 Left limit switch

2 Right limit switch

The reference point can be assigned to the positive (+) or negative (-) limit switch.

Dimensions

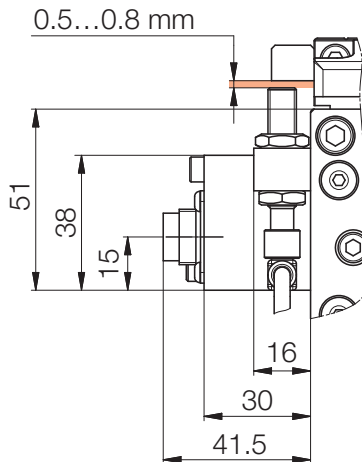

Special applications

Special applications often require a separate reference point switch, which is mounted between the positive and negative limit switches. The limit switch that is closer to the motor mounting (limit switch control interface) is referred to as the front limit switch.



NOTE

If the side support rail (type BM...L/R) is selected, the limit switches can only be mounted on the opposite side.

Connector pin assignment

The connector pin assignment when using a connector box is shown in the following diagram:

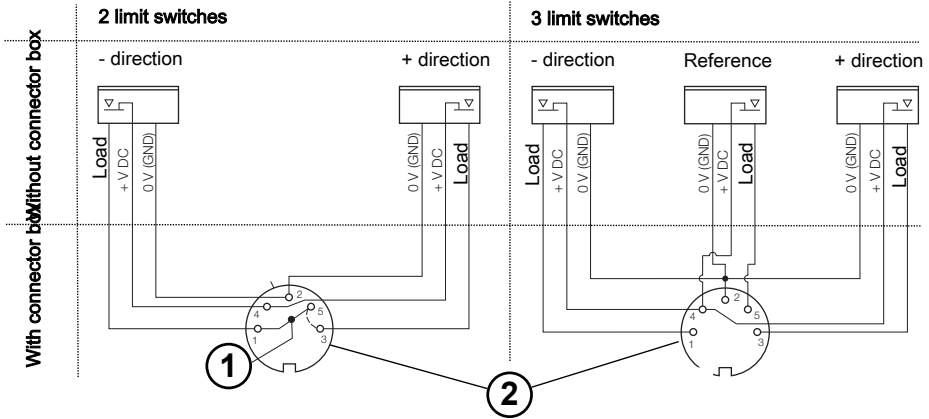

- 1 Reference point bridge
- Reference point in negative (–) direction forward (motor side)
Bridge pins 1 – 5
 - Reference point in positive (+) direction backward (motor opposite)
Bridge pins 3 – 5
- 2 SFV50 connector according to IEC 60130-9

The individual pins are assigned as follows:

- Pin 1 = negative (-) direction (load)
- Pin 2 = 0 V (GND)
- Pin 3 = positive (+) direction (load)
- Pin 4 = +10...30 V DC
- Pin 5 = Reference (load)

Color code legend

- Load = black
- +V DC = brown
- 0 V (GND) = blue

5.6.4 Limit switch mounting

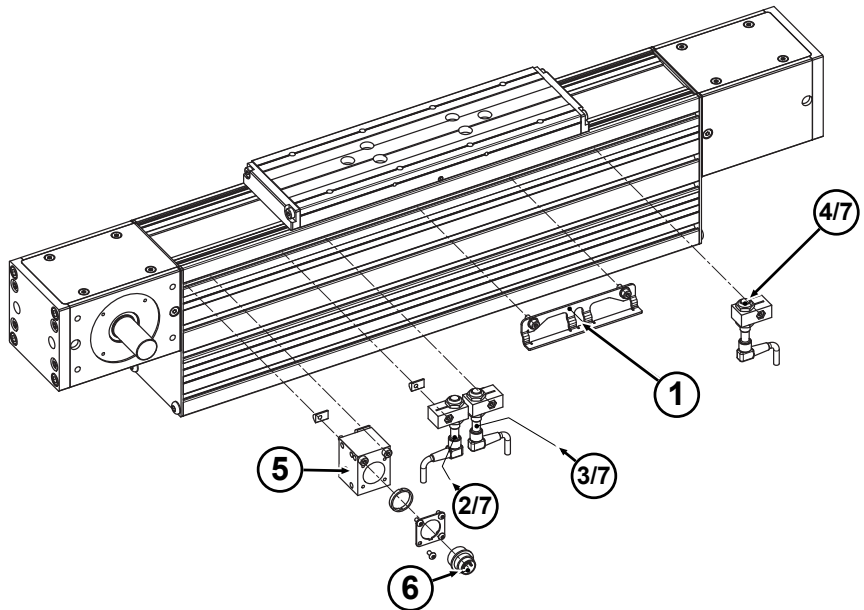

- | | | | |
|---|----------------------------|---|---------------------------|
| 1 | Switching lug | 2 | Negative limit switch (-) |
| 3 | Reference switch | 4 | Positive limit switch (+) |
| 5 | Connector box | 6 | Connector (incl. nut) |
| 7 | Limit switch cable (3-pin) | | |

When installing the limit switch, observe the tightening torques for the screws (see *Tightening torques for screws* [p. 60]).

5.7 Installing the motor and gearbox

5.7.1 General information



⚠ DANGER

Danger due to electric shock!

There is a risk of electric shock on contact with live components.

- ▶ Work on the electrical equipment must only be carried out by qualified electricians.
- ▶ De-energize the bridge module before carrying out any work (disconnect the power plug).



NOTE

Observe the information in the manufacturer's instructions regarding the motors and gearboxes to be installed.

5.7.2 Straight, with toothed belt drive

Motor mounting

Mount the motor as follows:

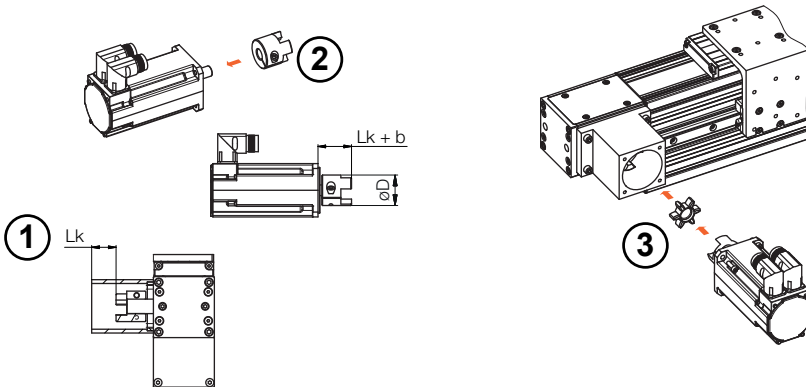

- a) Measure distance L_k on the unit (1).
- b) Attach the clamping hub to the motor mount at a distance of $L_k + b$ (2). Observe the tightening torque of the clamping screw.
- c) Mount the pre-assembled motor with gear rim to the unit (3).

Tightening torques of the clamping screw

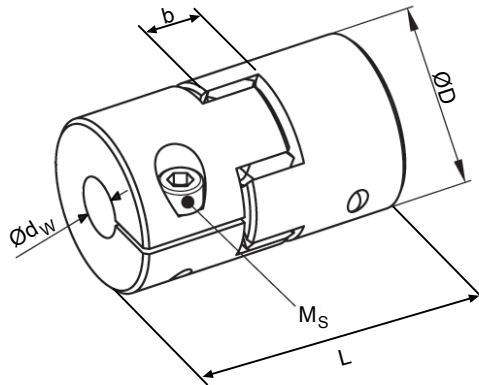

Size	Dimensions [mm]				Clamping screw tightening torque [Nm]		Drive torque [Nm]	
	L	$\varnothing D$	b	$\varnothing d_w$	Type	M_s	T_N	T_{max}
19	66	40	12	≤ 20	ISO 4762 (DIN 912)	10.10	17.0	34
19	66	40	12	≤ 20	ISO 7380	7.20	17.0	34

Motor attachments and parts list

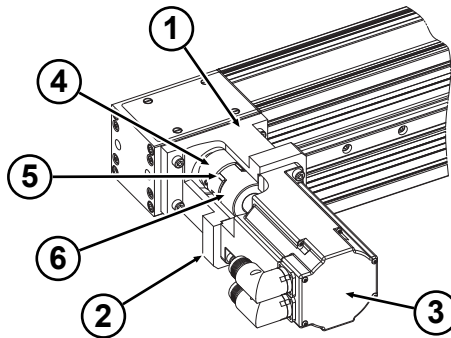

- | | | | |
|---|---------------------|---|----------------------|
| 1 | Intermediate flange | 2 | Motor plate |
| 3 | Motor | 4 | "BM" clamping hub |
| 5 | Gear rim | 6 | "Motor" clamping hub |

5.7.3 Gearbox mounting HPG...x1 and HPG...x2

Connection with external clamping set

Assemble gearboxes HPG...x1 and HPG...x2 as follows:

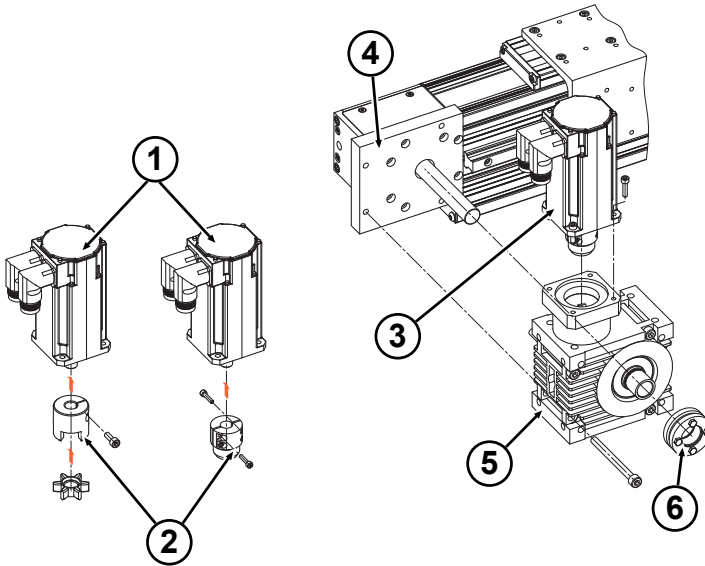

- | | | | |
|---|---------------------|---|------------------------|
| 1 | Motor | 2 | Coupling |
| 3 | Motor with coupling | 4 | Gearbox mounting plate |
| 5 | Gear unit | 6 | External clamping set |

- Assemble the coupling (2) to the motor (1).
- Assemble the gearbox (5) to the gearbox mounting plate (4).
- Assemble the external clamping set (6).
- Assemble the motor with the coupling (3) to the gearbox (5).

6 Operation

6.1 Safety



SAFETY INSTRUCTIONS

Working safely while operating the bridge module!

All work must be carried out in compliance with the safety instructions listed below:

- ▶ Comply with the provisions listed in the *Safety* [▶ 14]chapter for all work performed on/with the bridge module.
- ▶ Wear protective equipment in accordance with the accident prevention regulations at the operating site.
- ▶ Carry out all operating steps in accordance with the information in these assembly instructions.
- ▶ Before starting work, make sure that all covers and safety devices are installed and functioning properly.
- ▶ Never disable safety devices during operation.
- ▶ Keep the work area clean and tidy! Components and tools that are loosely stacked on top of each other or lying around create a risk of accidents.

6.2 Operating conditions

Normal operating conditions

Normal operating conditions		
Ambient temperature	5°...80°C (non-condensing)	 °C
Permissible operating temperature of components	Max. 80°C	(Excluding gearboxes/motors)
Travel speed	See <i>Permissible speeds</i> [▶ 61]	
Load	See <i>Technical data</i> [▶ 59]	
Minimum stroke	Type	Minimum stroke
	BM4	≥ 55mm

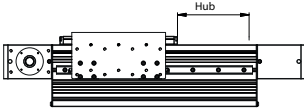

Special operating conditions

For applications in special operating conditions, such as moisture, dirt, dust (fiberglass and wood), aggressive atmospheres, extreme climatic conditions and/or strong temperature fluctuations, short strokes and others, contact LINE TECH AG before commissioning.

The specified maximum values refer to one domain. If several requirements are combined (temperature/speed/load), this must be taken into consideration in the design.

7 Maintenance

7.1 Safety



SAFETY INSTRUCTIONS

Working safely while maintaining the bridge module!

Carry out all work in compliance with the following safety instructions:

- ▶ Comply with the provisions listed in the *Safety* [▶ 14] chapter for all work performed on/with the bridge module.
- ▶ All maintenance work must only be carried out by specially trained personnel (see the *Personnel requirements* [▶ 16] chapter).
- ▶ Work on electrical systems must only be carried out by qualified electricians (see the *Qualifications* [▶ 16] chapter).
- ▶ Wear protective equipment in accordance with local accident prevention regulations for all maintenance work.
- ▶ Before starting work, switch off the electrical supply and secure it against being switched on again.
- ▶ Make sure that there is sufficient space for assembly before starting work.
- ▶ Make sure that the assembly area is tidy and clean! Components and tools that are loosely stacked on top of each other or lying around create a risk of accidents.
- ▶ If components have been removed or adjusted, ensure correct assembly, reinstall all fastening elements and observe the screw tightening torques.
- ▶ Observe the specified maintenance intervals.
- ▶ Observe the relevant environmental protection instructions.

7.2 Repairs



NOTE

Repairs to the bridge module are not considered maintenance work. They must only be carried out by trained specialist personnel or the manufacturer's service personnel.

7.3 Maintenance intervals

7.3.1 Notes

Carrying out

- the maintenance work prescribed on the following pages and
- of the maintenance work on purchased components in accordance with the relevant documentation

is required to ensure safe and smooth operation of the bridge module.

The specified maintenance intervals are based on our many years of experience and knowledge. If excessive wear of wear parts is detected or if faults occur more frequently, the operator must shorten the time between two maintenance procedures in an appropriate manner.

Keep a maintenance log to verify that the prescribed maintenance work has been performed.



NOTE

Verification that the required maintenance work has been carried out is a mandatory requirement for claiming any warranty services.

Contact the manufacturer if there are any doubts.

7.3.2 Maintenance schedule

Interval	Maintenance work	Description	Personnel
Daily	Check the bridge module for externally visible damage.	<i>Checking the bridge module for externally visible damage</i> [▶ 49]	Specialist personnel
Every 3 months	Lubricate bridge modules	<i>Lubricating bridge modules</i> [▶ 50]	Specialist personnel
as required	Tension the belt	<i>Tensioning the toothed belt</i> [▶ 53]	Specialist personnel

7.4 Maintenance work

7.4.1 Checking the bridge module for externally visible damage

Daily or before each use

- a) Check the bridge module for externally visible damage and defects.
- b) Visually check that externally attached fasteners, electrical cables and plug connections are in perfect working order.

If changes occur that put the safety of personnel and systems at risk, immediately shut down the bridge module.

7.4.2 Lubricating bridge modules

Lubricants

The bridge modules must only be lubricated with grease.

LINE TECH AG carries out the initial greasing procedure. The bearings used are generally maintenance-free and do not need to be relubricated under normal conditions.

LINE TECH AG recommends MICROLUBE GBU-Y 131 as the standard grease. When using other greases (third-party products), first check compatibility with the standard grease. Observe the safety data sheet.

For special operating conditions, please consult us regarding lubricant quantities. The values and information on lubricant quantities in the following table correspond to use under normal operating conditions.

Type	Grease	Grease relubrication quantities for guide carriage (cm ³) Lubrication point ^(1) or 3)	Lubrication point ⁽²⁾
BM..Z..N	Klüber MICROLUBE GBU-Y 131	3.50	-
BM..Z..L/R		3.50	1.75 (per carriage)

There are grease nipples on both sides of the carriage parts. It is sufficient to press in the grease from just one side.

Relubricate the guides according to the following table, depending on which value is reached first:

Type	Interval (months)	Running interval (km)
BM..Z..N	3 - 6	Depending on F/C ratio
BM..Z..L/R	3 - 6	Depending on F/C ratio

Lubrication (procedure)

Lubricate the bridge module as follows:

- Lubricate the table part(s).
- When lubricating with a hand press, calculate the amount of grease per stroke.
- After lubricating, remove excess grease with a clean cloth.

F/C ratio

The F/C ratio is determined by the load F calculated by the customer and divided by the corresponding load rating C.

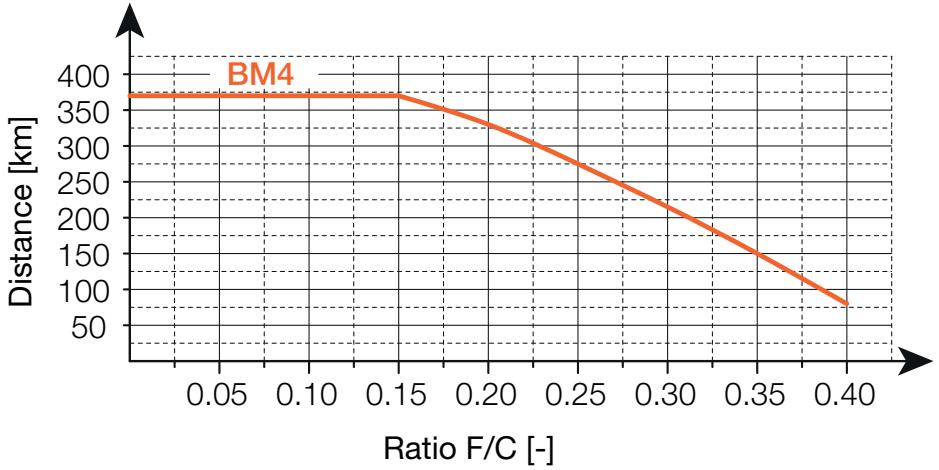

Bridge module type	Load ratings C [N]
BM..Z..N	34200
BM..Z..L/R	68400

Lubrication points

Various grease nipples are available on the bridge modules.

¹⁾ Grease nipples according to DIN 3405. The carriage positions for lubrication are independent of the stroke.

²⁾ Grease nipples according to DIN 71412. The carriage positions for lubrication are independent of the stroke

³⁾ Lubrication possible from either the left or right side.

To press in the lubricant, we recommend using the grease gun with item no.:
ZPE.FETTPRESSE.03

BM..Z..N

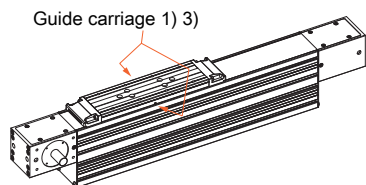

BM..Z..L/R

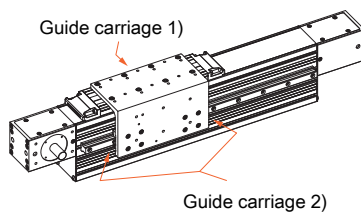

7.4.3 Tensioning the toothed belt

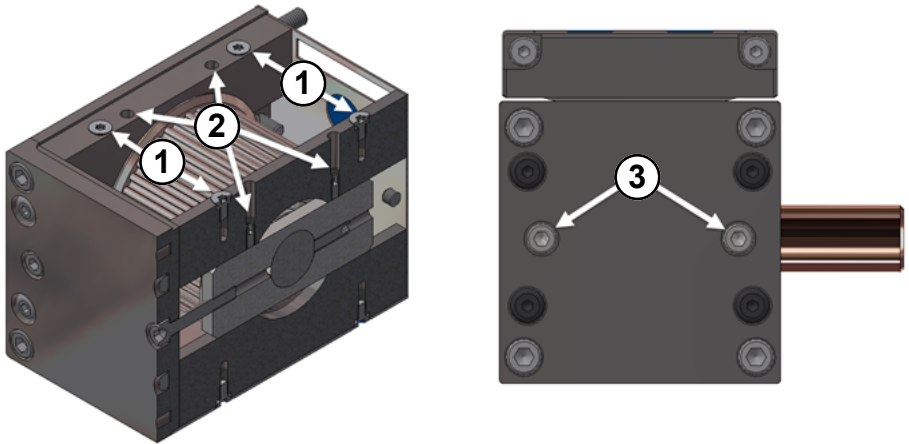

Tension the toothed belt as follows:

- a) Loosen the four countersunk screws (1) and remove the upper cover plate on the opposite side of the motor.
(4x DIN963 M4 / DIN EN ISO 2009 M4)
- b) Loosen four clamping screws (2) by at least 3 turns.
(4x DIN913 M4 / DIN EN ISO 4026 M4)
- c) Ensure that the toothed belt is centered in the tension roller.
- d) Tighten the tensioning screws (3) alternately to the specified torque (see table below).
(2x DIN912 / DIN EN ISO 4762)
- e) Ensure that the toothed belt runs in the center of the tension roller.
- f) Tighten the four clamping screws (2).
- g) Replace the cover plate and secure it with the four countersunk screws (1).

Bridge module	Tensioning screws	Belt designation	Torque [Nm]
BM4	M5	LL40GT5MR	2.0

7.5 Measures after completing the maintenance work

After completing the maintenance work and before switching the system on, carry out the following steps:

- a) Check that all previously loosened screw connections are tight.
- b) Check that all previously removed protective devices and covers have been properly reinstalled. Clean the work area and remove any substances that may have leaked, e.g., liquids, processing material or similar.
- c) Make sure that all tools, materials and other equipment that were used have been removed from the work area.
- d) Make sure that all safety equipment is in perfect working order.



DANGER

Danger to life due to premature reactivation!

There is a risk of injury to personnel located in or reaching into the danger zone if the device is switched on again.

- ▶ Before switching the system back on, make sure that there are no personnel in the danger zone or reaching into the danger zone.

8 Faults

8.1 Safety



SAFETY INSTRUCTIONS

Work safely during troubleshooting!

Carry out all work in compliance with the following safety instructions:

- ▶ Comply with the provisions listed in the *Safety* [▶ 14] chapter for all work performed on/with the bridge module.
- ▶ All troubleshooting work must only be carried out by specially trained personnel (see the *Personnel requirements* [▶ 16] chapter).
- ▶ Work on electrical systems must only be carried out by qualified personnel (see the *Qualifications* [▶ 16] chapter).
- ▶ Wear protective equipment in accordance with local accident prevention regulations for all troubleshooting work.
- ▶ Before starting work, switch off the electrical supply and secure it against being switched on again.
- ▶ Make sure that there is sufficient space for assembly before starting work.
- ▶ Make sure that the assembly area is tidy and clean! Components and tools that are loosely stacked on top of each other or lying around create a risk of accidents.
- ▶ If components have been removed or adjusted, ensure correct assembly, reinstall all fastening elements and observe the screw tightening torques.
- ▶ Observe the relevant environmental protection instructions.

8.2 Behavior if a fault represents a hazard

In general, the following applies:

- In case of faults that pose an immediate danger to people or property, switch off the machine immediately.
- Determine the cause of the fault and notify the person responsible at the operating site of the fault.
- If it is necessary to enter danger zones or reach into danger zones during troubleshooting work, secure the machine against being switched on again.
- Have the fault repaired by authorized qualified personnel.

8.3 Possible faults

Possible faults can be indicated by the following:

- Unusual noises
- Sluggish running
- Inaccuracies



NOTE

Contact LINE TECH AG service for troubleshooting (See reverse side) .

8.4 Measures after completing the troubleshooting work

After completing the troubleshooting work and before switching the machine back on, implement the following measures:

- Tighten all previously loosened screw connections.
- Make sure that any protective devices and covers that were previously removed are properly refitted.
- Make sure that all tools and work materials that were used have been removed from the work area.
- Clean the work area and remove any spilled substances, such as liquids, processing materials, or similar and dispose of them in an environmentally-friendly manner.
- Make sure that all safety equipment is properly installed and functional.



⚠ DANGER

Danger to life due to premature reactivation!

There is a risk of injury to personnel located in or reaching into the danger zone if the device is switched on again.

- ▶ Before switching the system back on, make sure that there are no personnel in the danger zone or reaching into the danger zone.

9 Disassembly and disposal

9.1 Safety



SAFETY INSTRUCTIONS

Working safely when disassembling and disposing of the machine!

All work must be carried out in compliance with the safety instructions listed below:

- ▶ Comply with the provisions listed in the *Safety* [▶ 14] chapter for all work performed on/with the bridge module.
- ▶ The disassembly work must only be carried out by specially trained personnel (see the *Personnel requirements* [▶ 16] chapter).
- ▶ Work on electrical systems must only be carried out by qualified electricians (see the *Qualifications* [▶ 16] chapter).
- ▶ Wear protective equipment in accordance with local accident prevention regulations for all disassembly and disposal work.
- ▶ Before starting disassembly, switch off the electrical supply and permanently disconnect it.
- ▶ Make sure there is sufficient space before starting work.
- ▶ Make sure that the work area is tidy and clean. Components and tools that are loosely stacked on top of each other or lying around create a risk of accidents. Be careful when handling exposed components that have sharp edges.
- ▶ Disassemble components correctly. Note the high dead weight of some components. Use lifting equipment if necessary. Secure components so that they do not fall or fall over.
- ▶ Incorrect handling of environmentally hazardous substances, especially incorrect disposal, can cause considerable damage to the environment. If environmentally hazardous substances are accidentally released into the environment, immediately take measures and notify the responsible local authority of the damage.

9.2 Decommissioning and disassembly

To decommission the bridge module:

- a) Switch off the power supply to the entire system and disconnect it from the power supply.
- b) If necessary, disconnect the pneumatic connections.

- c) Remove the bridge module.
- d) Store the bridge module (see chapter *Storage* [▶ 26]) or
- e) disassemble the bridge module into assemblies in compliance with the applicable local environmental protection regulations.

9.3 Disposal



NOTICE

Environmental damage in case of incorrect disposal!

Lubricants and other auxiliary materials are subject to hazardous waste treatment and must only be disposed of by authorized specialist companies! Have disassembled components recycled:

- ▶ Scrap metals.
- ▶ Have plastic elements recycled.
- ▶ Sort the remaining components according to their material properties and dispose of them separately. The local authorities or specialist disposal companies can provide information regarding environmentally friendly disposal.

Pretreat and dispose of components according to the following table:

Components	Pretreatment	Disposal
Mechanical components	Clean	Scrap
Greases	Strip, clean	See safety data sheet
Oils	Drain, pump out	See safety data sheet

10 Technical data

10.1 General technical data

LM	Travel speed		Areas of inertia		Max. stroke ⁶⁾	Cover strip	Feed and friction force	Moving mass
	Guide	Drive	I_y	I_z				
Type	V_{max} [m/s]	V_{max} [m/s]	[cm ⁴]	[cm ⁴]	[mm]		F_V [N]	m_b [kg]
BM4...N...N ⁵⁾	5.0	⁴⁾	708	332	6180	Without	10.00	2,100
						With	25.00	2,120
BM4...Z...N	5.0	⁴⁾	708	332	6180	Without	25.00	2,150
						With	30.00	2,170
BM4...Z...L/ R	5.0	⁴⁾	721	401	6180	Without	50.00	4,080
						With	60.00	4,100

⁴⁾For toothed belt drives, depending on the load and speed as well as the permissible travel speed of the guide, see *Permissible speeds* [▶ 61].

⁵⁾Version without drive

⁶⁾Larger strokes are optionally available with composite shell profiles.

10.2 Technical data for toothed belt drive

LM	Toothed belt drive				Axial load	Positioning accuracy	Repeatability	Acceleration
Size	Type Pitch	Toothed disc $d_3 \times l_R$ [mm]	Stroke/U [mm]	Tension F ³⁾ [N] [mm/m]		[μ /mm]	.../1000 [mm]	a_{max} [m/s ²]
BM4	HTD5M	65.25 x 45	205	0.105 ... ¹⁾		200/1000 ²⁾	<0.20 ²⁾	50.0 ¹⁾

$d_3 \times l_R$ = pinion diameter x pinion width

¹⁾depending on speed and load

²⁾without considering reverse play

³⁾belt tension/meter [mm/m] per 100 N tensile force

10.3 Tightening torques for screws

Screws of strength class 8.8 are used as standard. If other screws are used, they are specially marked. The tightening torques recommended by LINE TECH AG are defined in the following table.

Screw acc. to	Material class	Tightening torques $M_{A,max}$ [Nm]					Friction factor for screws $\mu = 0.120$				
		Thread size									
		M2	M2.5	M3	M4	M5	M6	M8	M10	M12	
ISO 4762 (DIN 912)	8.8	0.36	0.73	1.27	3.00	5.90	10.10	24.60	48.00	84.00	
ISO 4762 (DIN 912)	12.9	0.60	1.23	2.14	5.10	10.00	17.40	42.20	83.00	144.00	
ISO 47380	10.9	0.25	0.50	0.90	2.00	4.00	7.20	12.00	23.00	58.00	

10.4 Permissible speeds

When driven by a toothed belt, the permissible travel speed of the linear guide and the load are decisive. Also take the motor speed into account.

The following permissible speeds apply to the bridge module with toothed belt drive (BM4...Z...):

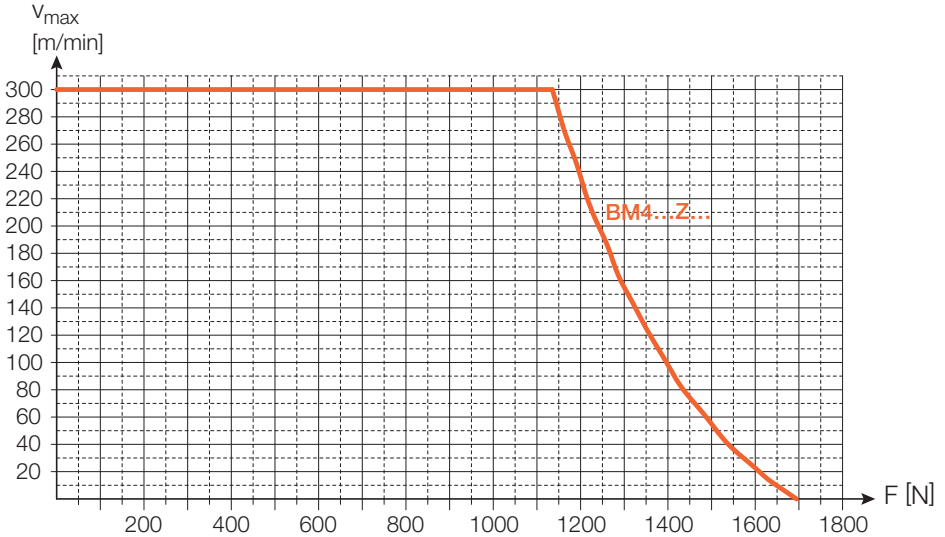

10.5 Bridge module: technical data

10.5.1 Exploded view and parts list for bridge module BM4...NZ...N with toothed belt drive, without cover strip

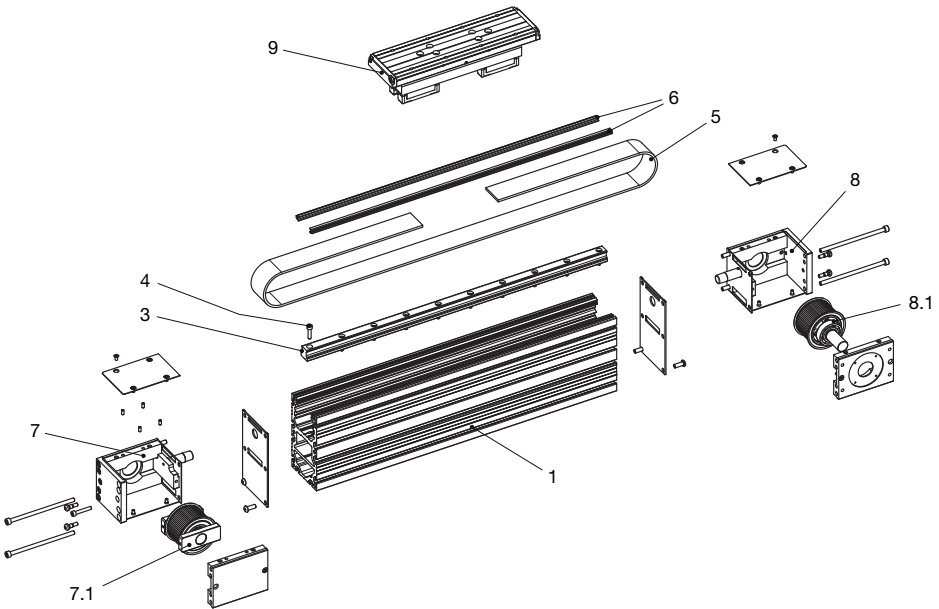

1	Casing profile	8.1	Drive sprocket kit
2	-	9	Carriage
3	Linear rail	10	-
4	Screw for linear rail	11	-
5	Toothed belt	12	-
6	Toothed belt guide profile	13	-
7	Deflection housing	14	-
7.1	Deflection sprocket kit	15	-
8	Drive housing	16	-

10.5.2 Exploded view and parts list for bridge module BM4...BZ...N with toothed belt drive, with cover strip

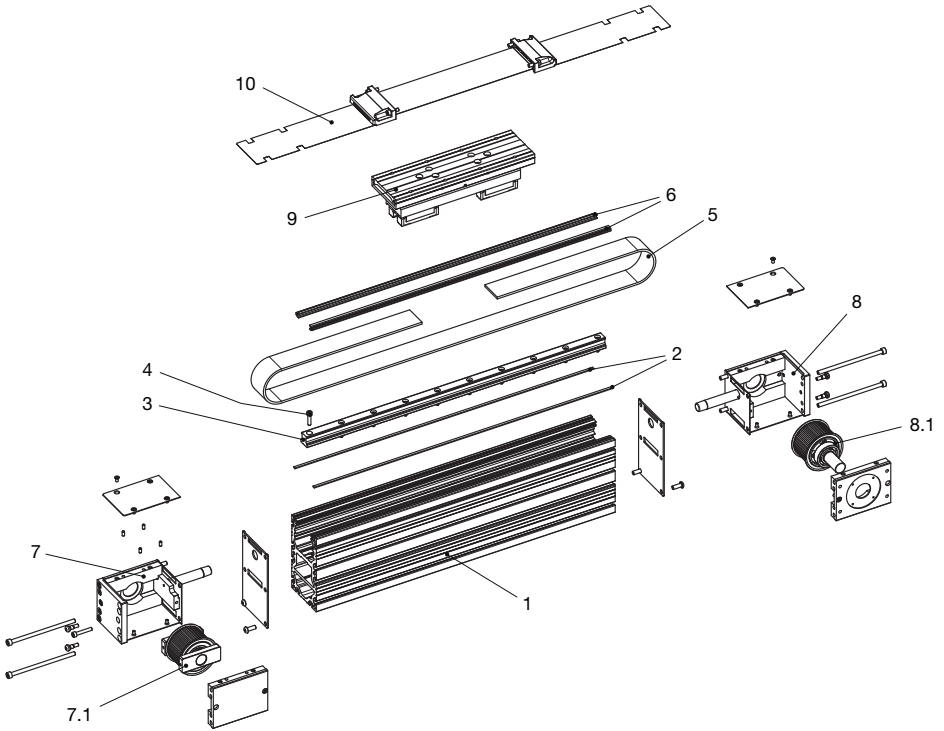

1	Casing profile	8.1	Drive sprocket kit
2	Magnetic tape	9	Carriage
3	Linear rail	10	Complete cover strip
4	Screw for linear rail	11	-
5	Toothed belt	12	-
6	Toothed belt guide profile	13	-
7	Deflection housing	14	-
7.1	Deflection sprocket kit	15	-
8	Drive housing	16	-

10.5.3 Exploded view and parts list for bridge module BM4...NZ...L/R

Linear modules with toothed belt drive and side support rails on the right/right, without cover strip

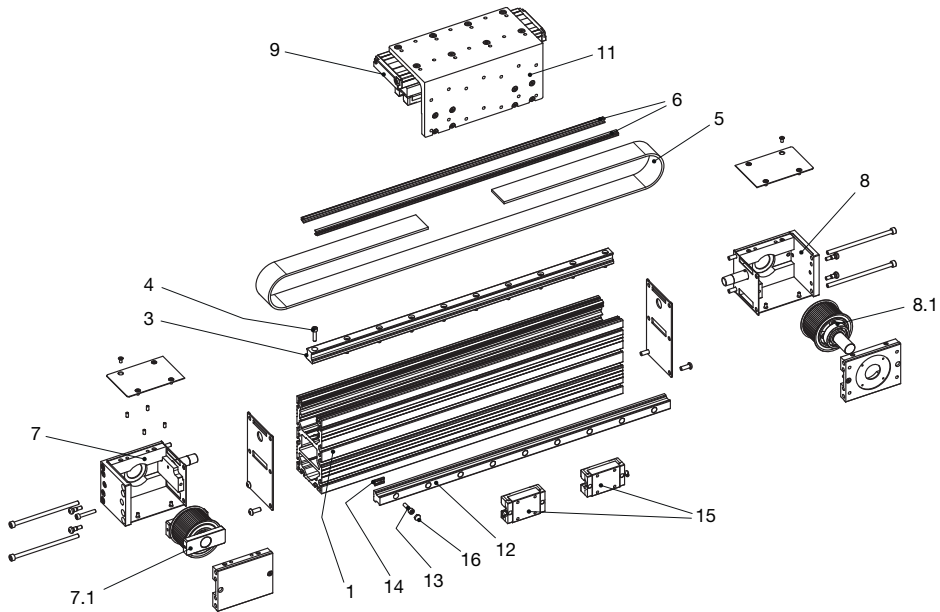

1	Casing profile	8.1	Drive sprocket kit
2	-	9	Carriage
3	Linear rail	10	-
4	Screw for linear rail	11	Angle bracket for support rail
5	Toothed belt	12	Support rail
6	Toothed belt guide profile	13	Screw for support rail
7	Deflection housing	14	T-slot nut for support rail
7.1	Deflection sprocket kit	15	Guide carriage for support rail
8	Drive housing	16	Cover cap for support rail

10.5.4 Exploded view and parts list for bridge module BM4..BZ..L/R with toothed belt drive and side support rails on the right/right, without cover strip

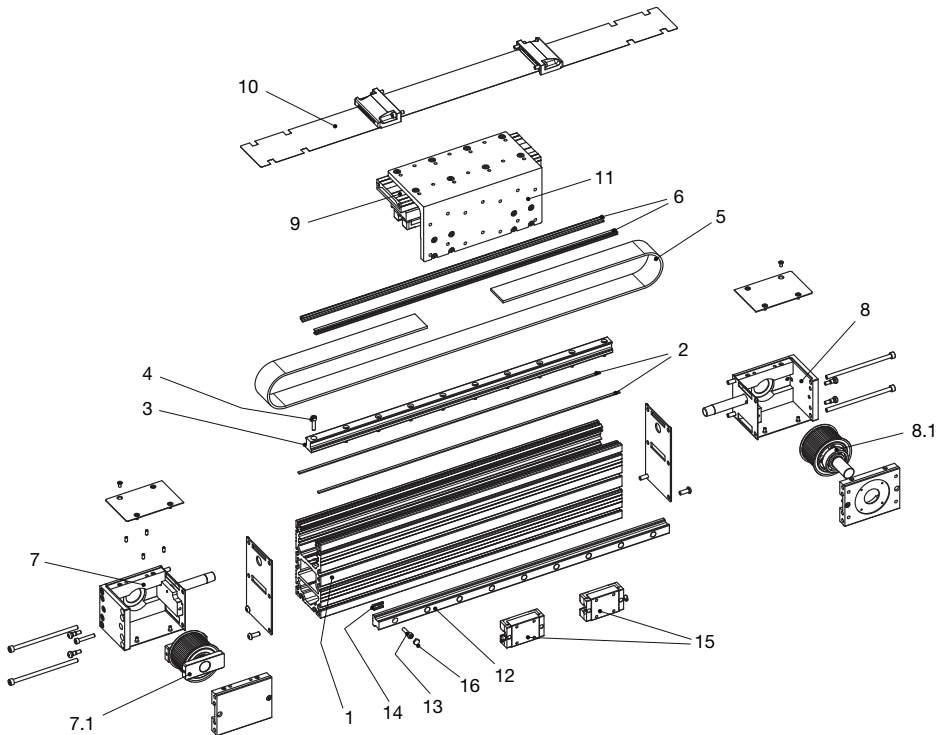

- | | | | |
|-----|----------------------------|-----|---------------------------------|
| 1 | Casing profile | 8.1 | Drive sprocket kit |
| 2 | Magnetic tape | 9 | Carriage |
| 3 | Linear rail | 10 | Complete cover strip |
| 4 | Screw for linear rail | 11 | Angle bracket for support rail |
| 5 | Toothed belt | 12 | Support rail |
| 6 | Toothed belt guide profile | 13 | Screw for support rail |
| 7 | Deflection housing | 14 | T-slot nut for support rail |
| 7.1 | Deflection sprocket kit | 15 | Guide carriage for support rail |
| 8 | Drive housing | 16 | Cover cap for support rail |

10.5.6 Linear module dimensions BM4...BZ...N

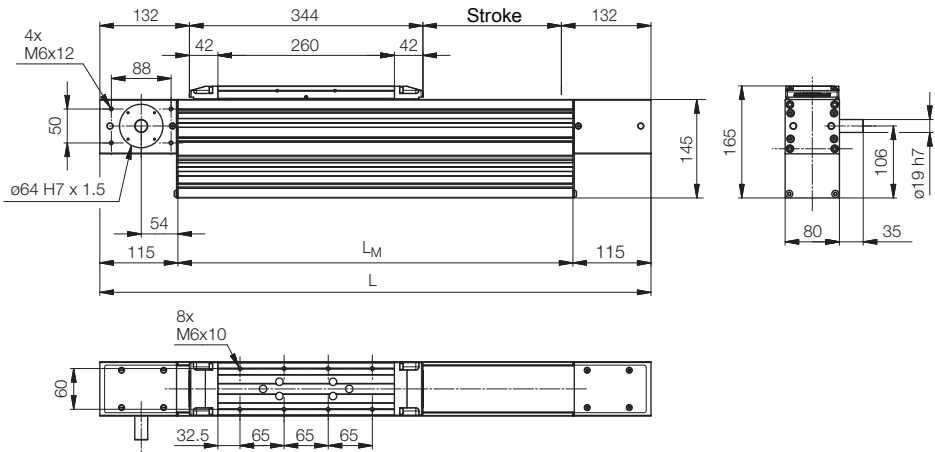

Nominal size Designation	Dimensions			Length of cover strip [mm]	Weight [kg]
	L [mm]	L_M [mm]	Belt length [mm]		
BM4...BZ...N	Stroke + 608	L - 230	2 x stroke + 1040	L - 12	10.7 kg + 1.38 kg/ 100 mm stroke

10.5.7 Linear module dimensions BM4...NZ...L/R

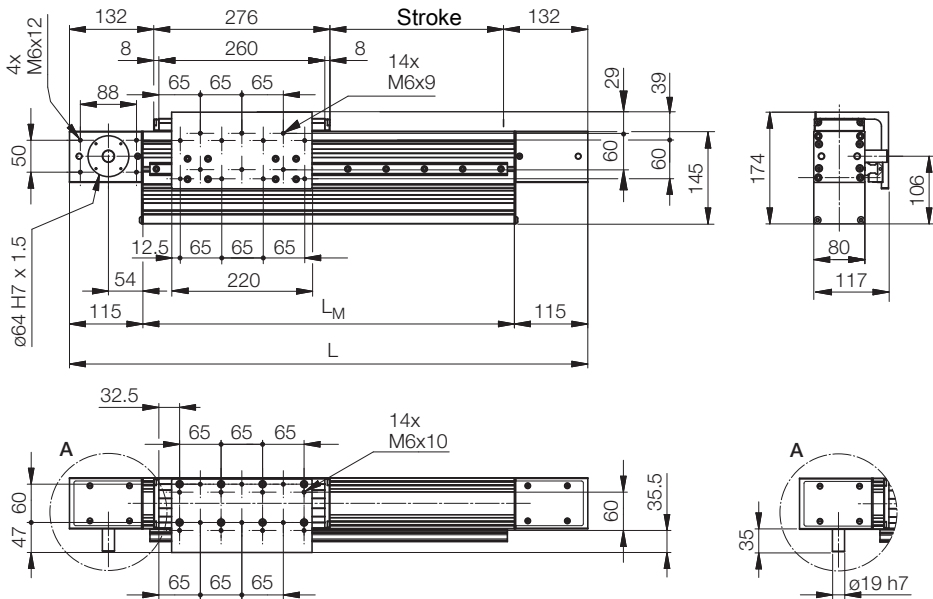

Nominal size Designation	Dimensions		Belt length [mm]	Weight [kg]
	L [mm]	L _M [mm]		
BM4...NZ...L/R	Stroke + 540	L - 230	2 x stroke + 900	12.39 kg + 1.59 kg/100 mm stroke

10.5.8 Linear module dimensions BM4...BZ...L/R

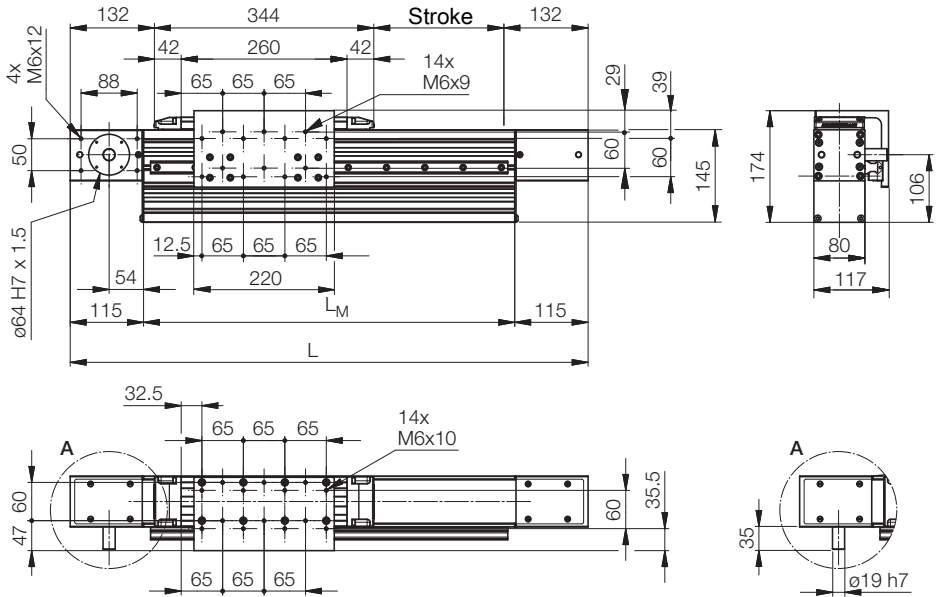

Nominal size Designation	Dimensions		Belt length [mm]	Length of cover strip [mm]	Weight [kg]
	L [mm]	L _M [mm]			
BM4...BZ...L/R	Stroke + 608	L - 230	2 x stroke + 1040	L - 12	13.54 kg + 1.61 kg/100 mm stroke

11 Declaration of Incorporation

Declaration of Incorporation

according to EC Machinery Directive 2006/42/EC, Annex II 1. B

(Translation of original Declaration of Incorporation)

Manufacturer

Line Tech AG

Europastrasse 19
CH-8152 Glattbrugg

Module name

Bridge module with toothed belt drive

Type designation

according to type plate (see *Type plate* [▶ 22])

Serial number

according to type plate (see *Type plate* [▶ 22])

Manufacturing date

according to type plate (see *Type plate* [▶ 22])

We hereby declare that

the product specified below complies with the essential safety requirements of the Machinery Directive, including the amendments applicable at the time of the declaration, to the extent permitted by the scope of delivery, due to its design, construction and type in the version that we have launched on the market.

The following essential safety requirements of the Machinery Directive have been satisfied:

- 1.1.2 Principles for the integration of safety
- 1.1.3 Materials and products
- 1.1.5 Design of the machine for handling
- 1.3.2 Risk of breakage during operation
- 1.3.3 Risks due to falling or ejected objects
- 1.3.4 Risks due to surfaces, edges and corners
- 1.3.7 Risks due to moving parts
- 1.3.9 Risk of uncontrolled movements
- 1.5.2 Static electricity
- 1.5.4 Assembly errors
- 1.5.5 Extreme temperature
- 1.5.6 Fire
- 1.5.8 Noise
- 1.5.13 Emission of hazardous materials and substances
- 1.6.1 Maintenance of the partly completed machinery
- 1.7.2 Warning of residual risks

The product is a partly completed machine as defined by the Machinery Directive. The product is solely intended for installation in a complete system.

Relevant EU directives

EC Directive as amended 2006/42/EC - Machinery Directive

EMC Directive as amended by 2014/30/EU - Electromagnetic compatibility

Applied harmonized standards

The machine complies with the safety requirements of the following harmonized standards:

DIN EN ISO 12100:03/2011: Safety of machinery - General principles for design - Risk assessment and risk reduction

Technical documentation

The specific technical documentation in accordance with Annex VII, Part B has been compiled. The representative responsible for compiling the technical documentation undertakes to submit the documentation to the national authorities upon justified request. The documentation shall be submitted by post in paper form or on an electronic data carrier.

Documentation Officer

Line Tech AG, Europastrasse 19, CH-8152 Glattbrugg

Commissioning

The product may not be commissioned until it has been established that the machine in which the aforementioned product is installed complies with all the essential requirements of the Machinery Directive.



Daniel Rees
(Head of Technology/Design)

LINE TECH AG
Europastrasse 19
CH-8152 Glattbrugg

Glattbrugg, October 2025

Keyword index

A

Accidents	13
-----------	----

C

Clamps	34
Connector box	37

D

Danger areas	16
Danger level	
Danger to life	7
Personal injury	8
Property damage	8
Risk of injury	8
Decommissioning	57
Deflection	33
Disposal	58
Documents; applicable	13

E

Environment	19
Environmental protection	19, 58

F

F/C ratio	51
Faults	13
Forklift	24

G

Gearbox assembly	31
Greases	19

H

Hearing protection	17, 19
--------------------	--------

I

Instructions	15
Intended use	14

L

Liability	11
Limit switches	37
Load ratings	21
Lubricants	19, 50
Lubrication	50
Lubrication points	52

M

Maintenance schedule	48
Manufacturer	16
Motor attachments	43
Motor mounting	31

N

Noise level	19
Note on working safely	9
Note regarding useful information	9

O

Obligations	10
Oils	19
Operating site	18
Operation	45
Original spare parts	12

P

Personal protective equipment	15, 16
personnel	
instructed	16
unauthorized	16
Personnel requirements	16
Pin assignment	39
Position of the limit switches	39
Product description	21
Protective clothing	17
Protective clothing; suitable	17
Protective gloves	17
Provisions	5

Q

Qualification	16
---------------	----

Qualified personnel	16
---------------------	----

R

Reading obligation	5
Reference switch	37
Repairs	48

S

Safety	15
Safety goggles	17
Safety shoes	17
Service center	16
Sliding blocks	36
Sources of information; additional	13
Spare parts	12
Storage	26
Storage location	5

T

Technical changes	10
Tightening torques of the clamping screw	43
Transport item	24
Type plate	22

W

Warning symbols	9
Electric current	9
Environmental pollution	9
Suspended load	9
Warranty claims	12
Warranty conditions	12

LINE TECH

Linear movements form the backbone of modern industrial production systems. LINE TECH AG has been providing linear technology solutions every day for over 25 years. LINE TECH AG is distinguished by a comprehensive range of components, linear and positioning systems coupled with the technical expertise of our employees.



Advanced services ranging from engineering to design, combined with flexible production, round off the product range and provide you, the customer, with a wide range of advantages.



Proprietary products

LINE TECH's proprietary products include modular, ready-to-install linear axes:

- Linear modules
- Bridge modules
- Compact units
- Positioning units



Systems / assemblies

Our engineering department develops customized solutions at the customer's request.



Components

Commercial products supplement the range, including linear guides, drives, and components:

- Linear guides
- Toothed belt drives
- Roller linear guides
- Ball bushings and shafts
- Ball rollers
- Comprehensive range of accessories
- Megatorque motors
- Linear motors

LINE TECH AG
Europastrasse 19
CH-8152 Glattbrugg
Switzerland

Telephone +41 (0) 43 211 68 68
Fax +41 (0) 43 211 68 69
info@linetech.ch

Revisionsstand:
1/22/2026

