

Translation of the original installation and maintenance instructions

COMPACT UNIT WITH BALL SCREW DRIVE



 Read the installation and maintenance instructions before carrying out any work!

Table of contents

| | | |
|----------|--|-----------|
| 1 | General information..... | 5 |
| 1.1 | Information about these assembly instructions..... | 5 |
| 1.2 | Notes on use..... | 6 |
| 1.3 | Structure of the warnings..... | 7 |
| 1.4 | Symbols used..... | 9 |
| 1.5 | Disclaimer..... | 10 |
| 1.6 | Spare parts..... | 12 |
| 1.7 | Warranty conditions..... | 12 |
| 1.8 | Customer service and product monitoring..... | 13 |
| 1.9 | Applicable documents..... | 13 |
| 2 | Safety..... | 14 |
| 2.1 | Introduction..... | 14 |
| 2.2 | Intended use..... | 14 |
| 2.3 | Foreseeable misuse..... | 14 |
| 2.4 | Responsibility of the operator..... | 15 |
| 2.5 | Personnel requirements..... | 16 |
| 2.5.1 | General personnel requirements..... | 16 |
| 2.5.2 | Qualifications..... | 16 |
| 2.5.3 | Unauthorized personnel..... | 16 |
| 2.6 | Personal protective equipment..... | 16 |
| 2.7 | Residual risks..... | 18 |
| 2.7.1 | Note..... | 18 |
| 2.7.2 | Mechanical hazards..... | 18 |
| 2.7.3 | Hazards at the operating site..... | 18 |
| 2.7.4 | Hazards due to noise..... | 19 |
| 2.8 | Environmental protection..... | 19 |
| 3 | Structure and function..... | 20 |
| 3.1 | Product overview..... | 20 |
| 3.2 | Product description..... | 21 |
| 3.3 | Type plate..... | 22 |
| 4 | Transport..... | 23 |
| 4.1 | Safety..... | 23 |
| 4.2 | Transport by forklift..... | 24 |
| 4.3 | Transport with the crane..... | 24 |
| 4.4 | Transport inspection and scope of delivery..... | 25 |
| 4.5 | Storage..... | 26 |
| 5 | Assembly..... | 27 |
| 5.1 | Safety..... | 27 |
| 5.2 | Delivery configurations..... | 28 |

| | | |
|-----------|---|-----------|
| 5.3 | Permissible deflection with toothed belt drive | 30 |
| 5.4 | Attaching the compact unit | 33 |
| 5.4.1 | General information | 33 |
| 5.4.2 | Attaching the compact unit using clamping flanges | 33 |
| 5.4.3 | Attaching the compact unit using clamping flanges | 35 |
| 5.5 | Assembling limit switches | 36 |
| 5.5.1 | Limit switch assembly | 36 |
| 5.5.2 | Overview of limit switch/reference switch installation | 37 |
| 5.5.3 | Position of the limit switches | 38 |
| 5.6 | Installing the motor and gearbox | 40 |
| 5.6.1 | General information | 40 |
| 5.6.2 | Straight with ball screw | 40 |
| 5.6.3 | Side, with ball screw drive | 42 |
| 5.6.4 | Calculation of the preload frequency | 44 |
| 5.6.5 | Connecting plates | 46 |
| 5.6.6 | Cross table | 50 |
| 6 | Operation | 52 |
| 6.1 | Safety | 52 |
| 6.2 | Operating conditions | 53 |
| 7 | Maintenance | 54 |
| 7.1 | Safety | 54 |
| 7.2 | Repairs | 55 |
| 7.3 | Maintenance intervals | 55 |
| 7.3.1 | Notes | 55 |
| 7.3.2 | Maintenance schedule | 56 |
| 7.4 | Maintenance work | 56 |
| 7.4.1 | Checking the compact unit for externally visible damage | 56 |
| 7.4.2 | Lubricating the compact unit | 57 |
| 7.5 | Measures after completing the maintenance work | 60 |
| 8 | Faults | 61 |
| 8.1 | Safety | 61 |
| 8.2 | Behavior if a fault represents a hazard | 61 |
| 8.3 | Possible faults | 62 |
| 8.4 | Measures after completing the troubleshooting work | 62 |
| 9 | Disassembly and disposal | 63 |
| 9.1 | Safety | 63 |
| 9.2 | Decommissioning and disassembly | 63 |
| 9.3 | Disposal | 64 |
| 10 | Technical data | 65 |
| 10.1 | General technical data | 65 |
| 10.2 | Technical data of ball screw drive | 66 |

| | | |
|-----------|---|-----------|
| 10.3 | Tightening torques for screws..... | 67 |
| 10.4 | Permissible speeds..... | 67 |
| 10.5 | Compact unit: technical data..... | 69 |
| 10.5.1 | Exploded drawing and parts list KE1.2...AR..... | 69 |
| 10.5.2 | Exploded drawing and parts list KE2.2...AR..... | 71 |
| 10.5.3 | Exploded drawing and parts list KE2.4...AR..... | 73 |
| 10.5.4 | Exploded drawing and parts list KE3.2...AR..... | 75 |
| 10.5.5 | Exploded drawing and parts list KE3.4...AR..... | 77 |
| 10.5.6 | Dimensions KE1.2...AR..... | 79 |
| 10.5.7 | Dimensions KE1.4...AR..... | 80 |
| 10.5.8 | Dimensions KE2.2...AR..... | 81 |
| 10.5.9 | Dimensions KE2.4...AR..... | 82 |
| 10.5.10 | Dimensions KE3.2...AR..... | 83 |
| 10.5.11 | Dimensions KE3.4...AR..... | 84 |
| 11 | Declaration of Incorporation..... | 85 |
| | Keyword index | 88 |

This document is protected by copyright and is intended for internal use only. Any provision of the document to third parties, any mode or form of reproduction – including excerpts –, any use and/or communication of the content, as well as translation into other languages, is not permitted without the prior consent of the manufacturer unless it is exclusively for internal use.

1 General information

1.1 Information about these assembly instructions

Using the assembly instructions

These assembly instructions allow you to work safely and efficiently with the compact unit throughout all phases of the compact unit's service life. All warnings and instructions in these assembly instructions must be observed in order to ensure safe working conditions.

Reading obligation

The operating/maintenance personnel are required to carefully read and understand these assembly instructions before starting any work.

Storage location

The assembly instructions are an integral part of the compact unit and must be kept readily available to the relevant personnel in the immediate vicinity of the compact unit.

Resale

If the compact unit is resold to a third party, these assembly instructions must also be included.

Applicable documents, regulations and provisions

In addition to these assembly instructions, the instructions, notes and signs on the compact unit in the annex also apply. Attach any notes on technical changes to these assembly instructions. In addition, the local accident prevention regulations and general safety requirements for the area where the compact unit is used apply.

Figures in these assembly instructions

Figures contained in these assembly instructions are provided for basic understanding and may vary from the actual version of the compact unit.

Loss of the assembly instructions

If the assembly instructions are lost, request a replacement set immediately. Contact details Legal notice (See reverse side) .

1.2 Notes on use

Instructions and steps

Steps to be performed by the operating personnel are shown consecutively. The sequence of steps must be observed.

Example:

a) Step 1

Lists

Lists without a mandatory sequence of steps are shown as a list preceded by a bullet point.

Example:

- Item 1
 - Item 1, subitem A
- Item 2

Lists with a mandatory sequence of steps are shown as a list preceded by numbers.

Example:

1. First
2. Second

References to chapters/pages

References to specific chapters in which procedures and instructions are described are displayed as active links.

Example: see chapter *Information about these assembly instructions* [[▶](#) 5].

Illustrations

All figures and drawings in these assembly instructions are intended for general illustration purposes. They may vary from the actual design of the compact unit.

1.3 Structure of the warnings

The warnings used in these assembly instructions are introduced by signal words that indicate the extent of the danger.

The warning symbol additionally indicates the type of hazard.

The following warnings are used in these assembly instructions:

Danger level: Danger to life



| | |
|---|--|
| ⚠ DANGER | |
| <p>Danger to life!</p> <p>Consequences in case of non-compliance...</p> <p>▶ Notes on prevention</p> | |

A warning with this danger level indicates an imminent dangerous situation.

If the dangerous situation is not avoided, it will result in death or serious injury.

Follow the instructions in this warning to avoid the risk of death or serious personal injuries.

Danger level: Risk of injury**⚠WARNING****Risk of injury!**

Consequences in case of non-compliance...

- ▶ Notes on prevention

A warning with this danger level indicates a potentially dangerous situation.

If the dangerous situation is not avoided, it may result in death or serious injury.

Follow the instructions in this warning to avoid the possible risk of death or serious personal injuries.

Danger level: Personal injury**⚠CAUTION****Personal injury due to...**

Consequences in case of non-compliance...

- ▶ Notes on prevention

A warning with this danger level indicates a potentially dangerous situation.

If the dangerous situation is not avoided, it may result in minor or moderate injuries.

Follow the instructions in this warning to avoid personal injuries.

Danger level: Property damage**NOTICE****Property damage due to...**

Consequences in case of non-compliance...

- ▶ Notes on prevention

A warning with this danger level indicates possible material damage.

If the situation is not avoided, material damage may occur.

Follow the instructions in this warning to avoid material damage.

Note on working safely



| SAFETY INSTRUCTIONS |
|---|
| <p>Working safely during...!</p> <p>Carry out all work in compliance with the following safety instructions:</p> <ul style="list-style-type: none"> ▶ Notes on working safely |

This note contains important information and instructions for working safely during the following steps.

Follow the instructions in this note to avoid accidents and injuries.

Note regarding useful information



| NOTE |
|---|
| <p>Note text...</p> <p>Consequences</p> |

A note indicates additional information that is important for further processing or simplifies the described step.





1.4 Symbols used

Warnings in these assembly instructions are also marked with warning symbols.

Warning symbols

The following warning symbols are used in these assembly instructions:

| Symbol | Meaning |
|--------|-------------------------------|
| | General warning message |
| | Warning of electrical voltage |

| Symbol | Meaning |
|--|------------------------------------|
|  | Warning of hand injuries |
|  | Warning of heavy loads |
|  | Warning of suspended load |
|  | Warning of environmental pollution |

1.5 Disclaimer

Information in these assembly instructions

The information and warnings contained in these assembly instructions have been compiled taking into consideration the applicable standards, guidelines and regulations, the state of the art as well as our many years of experience. The scope of delivery or the design of the compact unit may vary from the descriptions and figures provided here due to optional order items, the production of customized designs or the latest technical changes.

Obligations

In addition to the contractually agreed obligations, the manufacturer's General Terms and Conditions of Business and Delivery apply. They are subject to the laws in force at the time when the contract is concluded.

Technical changes

The date of issue of these assembly instructions applies. We reserve the right to make technical changes to the compact unit within the scope of further development in order to improve its performance features and safety.

Disclaimer in case of non-compliance

The manufacturer is not liable for damage and accidents resulting from the following:

- Non-intended use (*Intended use* [► 14]) of the compact unit
- Non-compliance with the information and instructions in these assembly instructions
- Work performed on or with the compact unit by unqualified or unauthorized personnel
- Installation of non-original spare parts
- Unauthorized modifications without written acceptance by the manufacturer

1.6 Spare parts

Spare parts must be ordered from the manufacturer. See the reverse side for contact details.



⚠ CAUTION

Incorrect or faulty spare parts.

Risk of injury, risk of damage, malfunctions or total failure!

- ▶ Only use original spare parts from the manufacturer or spare parts approved by the manufacturer.
- ▶ If in doubt, contact the manufacturer.



NOTE

If non-approved spare parts are used, all warranty, service, compensation and/or liability claims against the manufacturer or its agents, dealers and representatives will be invalidated.

For all requests for spare parts or when ordering spare parts, always provide the complete data on the type plate (*Type plate* ▶ 22).

1.7 Warranty conditions

Location

The warranty conditions are included in the purchase contract and the manufacturer's General Terms and Conditions.

Basic information

The manufacturer or sales partner will make the final decision on a warranty claim after all defective parts have been returned or possibly after an on-site inspection. The replacement of defective parts does not extend the warranty period for the compact unit. In case of modifications or significant repairs carried out by the operator or third parties without the written consent of the manufacturer or sales partner, the warranty claim will be completely invalidated.

1.8 Customer service and product monitoring

Customer service

For problems and questions that cannot be solved using these assembly instructions and for technical information, please contact our customer service or sales partner; contact details (See reverse side) .

Product monitoring

We aim to continuously improve our products and are also interested in any experience gathered when using the compact unit.

We are happy to receive information about problems with the compact unit, faults during operation and errors that occur.

Always notify the manufacturer in the event of actual or potential accidents.

1.9 Applicable documents

In addition to the information contained in these assembly instructions, the information contained in the following sources of information, in particular the safety instructions, must also be taken into consideration:

- Information on the type plate of the compact unit
- Instructions for the assemblies used
- Instructions of the operator
- Safety data sheets of auxiliary and operating materials
- Local accident prevention regulations and regional regulations at the operating site of the compact unit
- Data sheets of installed components

2 Safety

2.1 Introduction

This section provides an overview of all the important safety aspects for ensuring optimum protection of personnel and for safe and smooth operation.

Failure to observe the instructions and warnings in these assembly instructions can result in serious hazards.

Only those risks that have been determined based on a risk assessment can be considered in these assembly instructions. Risks that result from work conditions, the place of deployment and interfaces to foreign components must be determined and warnings must be supplemented accordingly.

2.2 Intended use

The compact unit is solely intended for use in industrial applications.

The compact unit is solely intended for installation in machines and is used to move, precisely position and transport light to medium loads.

The permissible values specified in the "" chapter must be observed.

Any other use or use that goes beyond this is considered improper use.

2.3 Foreseeable misuse

Any use for a purpose other than the one specified in the *Intended use* [▶ 14] chapter is considered improper use.

Any use of the compact unit that goes beyond and/or deviates from the intended use can result in dangerous situations.

The risk of improper use or misuse is borne solely by the operating company.

Misuse occurs, for example, when

- The compact unit is operated outside the limits specified in *Technical data* [▶ 65].
- Modifications are made to the compact unit.
- Safety devices are disabled.
- The compact unit is used in an explosion-protected area.

2.4 Responsibility of the operator

Basic information

The owner of the compact unit is generally subject to the legal requirements concerning occupational safety, since the compact unit is intended for use in the commercial sector. In addition to the warnings in these assembly instructions, the safety, accident prevention and environmental protection regulations applicable to the area in which the compact unit is used must therefore also be observed.

Risk assessment

The operating company must keep itself informed of the applicable health and safety regulations and carry out a risk assessment to determine any additional hazards arising from the specific working conditions at the place where the compact unit is used.

Instructions

The operator must issue, implement, and document operating instructions based on the results of the risk assessment at the workplace.

During the entire time the compact unit is in use, the operating company is responsible for ensuring that the instructions it issues comply with the current legal requirements.

Responsibilities

The operating company must regulate the responsibilities for work on or with the compact unit and designate a person responsible for its safe operation and for coordinating all related activities.

Information flow

The operating company must ensure that all personnel working on or with the compact unit have read and understood these assembly instructions and other instructions. In addition, the operator must train the relevant personnel at regular intervals and inform them about the potential dangers.

Personal protective equipment

The operator must provide the personnel with the required personal protective equipment.

Safety requirements

If necessary, the operating company must ensure that the machine in which this compact unit is to be installed, or of which it is a component, complies with the basic safety requirements and provisions of all relevant directives before commissioning.

Perfect working order

In order to keep the compact unit in perfect working order at all times, the operating company must ensure that the maintenance intervals specified in these assembly instructions are observed.

2.5 Personnel requirements

2.5.1 General personnel requirements

Only persons who reliably perform their work and whose ability to react is not influenced, e.g., by drugs, alcohol or medication, are permitted to work on or with the machine.

When selecting such personnel, the job-specific age requirements applicable at the location where the compact unit is used must be observed.

2.5.2 Qualifications

Improper handling due to insufficient qualification can result in significant injuries.

- Have all activities performed out only by qualified personnel.
- Keep unqualified personnel away from the danger areas.

The following qualifications are specified in the assembly instructions for various areas of activity:

Qualified specialist personnel

Qualified specialist personnel can carry out the assigned work and independently identify and avoid potential hazards due to their specialist training, knowledge and experience as well as knowledge of the relevant standards and regulations.

Manufacturer (Service center)

Some work must only be carried out by the manufacturer's qualified personnel. Other personnel are not authorized to perform this work. Contact the manufacturer's service department to carry out the necessary work (see the Legal notice on the reverse side).

Instructed person (operator)

An instructed person has been informed by the operator about the tasks assigned to them and about possible dangers in the event of improper behavior.

2.5.3 Unauthorized personnel

Unauthorized personnel who do not meet the requirements described here are not aware of the dangers in the work area.

- Keep unauthorized personnel away from the work area.
- In case of doubt, address the personnel and direct them away from the work area.
- Stop working as long as unauthorized personnel are in the work area.

2.6 Personal protective equipment

Some work requires personnel to wear personal protective equipment to minimize health hazards. In addition to the personal protective equipment specified in these assembly instructions, the instructions posted in the work area must be observed. The following personal protective equipment must be worn depending on the work to be performed:

| Symbols | Meaning |
|---|--|
|  | <p>Suitable protective clothing is close-fitting work clothing with low tear resistance, tight sleeves and no parts that stick out. It is primarily used to protect against being caught by moving machine parts. Do not wear rings, chains or other jewelry.</p> |
|  | <p>Safety shoes are used to protect against heavy falling parts and slipping on slippery surfaces.</p> |
|  | <p>Protective gloves are used to protect hands from friction, abrasions, punctures or deeper injuries, as well as from contact with hot surfaces.</p> |
|  | <p>Hearing protection is used to protect hearing in case of potentially harmful noise levels.</p> |
|  | <p>Safety goggles are used to protect the eyes from flying small parts, dust or compressed air.</p> |



NOTE

External visitors or employees from other departments must also wear personal protective equipment when entering the work area.

2.7 Residual risks

2.7.1 Note

The following section identifies residual risks that have been identified based on a risk assessment.



SAFETY INSTRUCTIONS

Note on working safely!

Failure to observe the safety instructions, warnings and working instructions provided in these operating instructions may result in significant hazards.

- ▶ Always observe the safety instructions, warnings and handling instructions!
- ▶ Also observe the safety instructions provided in the other applicable documents!

2.7.2 Mechanical hazards

Moving compact units

Risk of injury between moving compact unit parts!

Parts of the body can get trapped or crushed between moving compact unit parts.

- Do not reach into moving compact unit parts during operation. Do not handle moving compact unit parts.
- Do not open covers during operation.
- Observe the lag time: make sure that no parts are moving before opening the covers.
- Wear close-fitting clothing and tie up long hair.

2.7.3 Hazards at the operating site

Operating the compact unit at an unsuitable or insufficiently equipped operating site poses various hazards!

Safety deficiencies caused by work performed incorrectly due to inadequate lighting:

- Make sure that there is sufficient lighting at the workplace.
- Have defective lamps replaced immediately.

Sharp edges, corners and materials with sharp edges can cause abrasions and cuts on the skin::

- Exercise caution when working near sharp edges and corners and when handling materials with sharp edges.
- In case of doubt, wear protective gloves.

Contamination and objects lying around create sources of slipping and tripping:

- Always keep the work area clean.
- Remove items that are no longer needed.

- Mark tripping hazards with yellow and black marking tape.
- Remove any spilled liquids immediately.

Danger of short circuits due to unsuitable application area:

- Only operate the compact unit indoors.
- Protect the compact unit from moisture.

2.7.4 Hazards due to noise

The compact unit itself does not emit any hazardous noise emissions. However, during operation in combination with the connected machines, noise levels may occur that could potentially lead to tinnitus or hearing loss.

- The emissions must be measured by the operator after the entire system has been assembled:
 - If the measured noise level is ≥ 80 dB(A), the operating company must make hearing protection available.
 - If the measured noise level is ≥ 85 dB(A), the operating company must make the use of hearing protection mandatory.

2.8 Environmental protection

Danger to the environment due to the improper handling of environmentally hazardous substances, especially their incorrect disposal:

- Always follow the instructions provided below.
- If environmentally hazardous substances are accidentally released into the environment, take appropriate measures immediately. In case of doubt, notify the responsible authority of the damage.
- Collect, transport and store environmentally hazardous substances in suitable containers only.

The following environmentally hazardous substances are used:

Lubricants

Lubricants such as greases and oils contain toxic substances. They must not be released into the . They must be disposed of by a specialist disposal company in accordance with local applicable regulations.

Machine parts

Replaced machine parts may, for example, be contaminated by grease and oil and therefore contain toxic substances. They must not be released into the environment. They must be disposed of by a specialist disposal company in accordance with local applicable regulations.

3 Structure and function

3.1 Product overview

The following exploded view shows a compact unit unit in its maximum configuration. The actual scope of delivery may vary from this version.

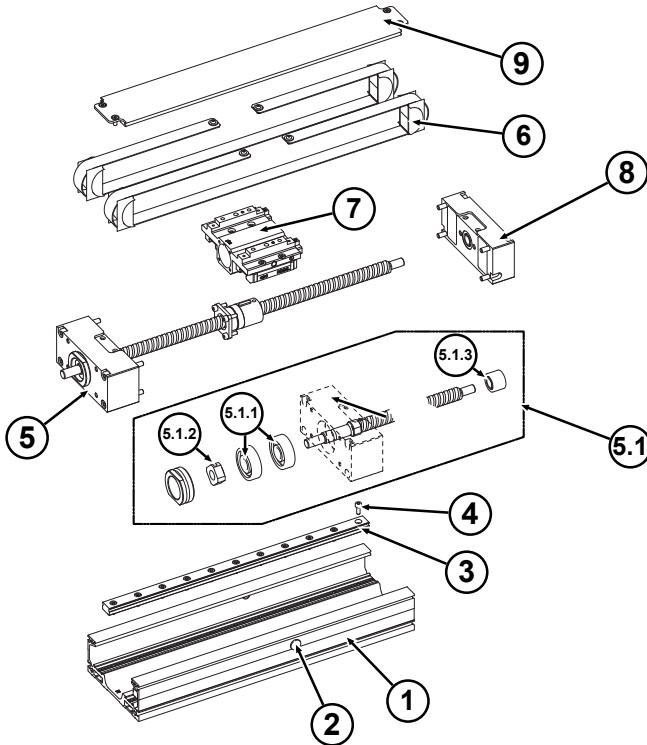

- | | | | |
|-------|---------------------------------|-------|------------------------------|
| 1 | Casing profile | 2 | Sealing plug |
| 3 | Linear rail | 4 | Screw for linear rail |
| 5 | End plate with ball screw drive | 5.1 | Complete ball screw drive |
| 5.1.1 | Angular contact ball bearing | 5.1.2 | Lock nut |
| 5.1.3 | Needle bearing | 6 | Cover strips, complete |
| 7 | Front carriage | 8 | End plate opposite the motor |
| 9 | Cover profile | | |

3.2 Product description

LINE TECH compact units with ball screw drives are modular, ready-to-install linear slides with drives, available in any required length. Sealed guide elements are used in all sizes. The base profile is made of an aluminum alloy and is manufactured via an extrusion process.

Additional externally mounted limit switches, in combination with motors and a control system, ensure the correct positioning of the carriage and protect against overrun.

The following load ratings are achieved:

KE...N...

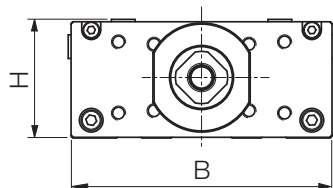

KE...V...

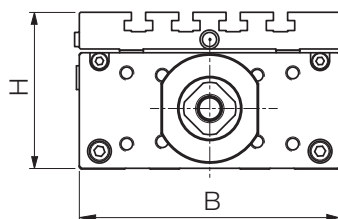

| Compact unit Type | Dimensions W x H [mm] | Load ratings | |
|----------------------|-----------------------------|------------------------|-----------|
| | | C ₀ [kN] | C [kN] |
| KE1.2...N... | 90 x 40 | 11.2 | 6.5 |
| KE1.2...V... | 90 x 56 | 11.2 | 6.5 |
| KE1.4...N... | 90 x 40 | 22.5 | 13.0 |
| KE1.4...V... | 90 x 56 | 22.5 | 13.0 |
| KE2.2...N... | 110 x 50 | 35.0 | 18.0 |
| KE2.2...V... | 110 x 66 | 35.0 | 18.0 |
| KE2.4...N... | 110 x 50 | 70.0 | 36.0 |
| KE2.4...V... | 110 x 66 | 70.0 | 36.0 |
| KE3.2...N... | 145 x 65 | 59.9 | 34.2 |
| KE3.2...V... | 145 x 85 | 59.9 | 34.2 |
| KE3.4...N... | 145 x 65 | 119.9 | 68.4 |
| KE3.4...V... | 145 x 85 | 119.9 | 68.4 |

3.3 Type plate

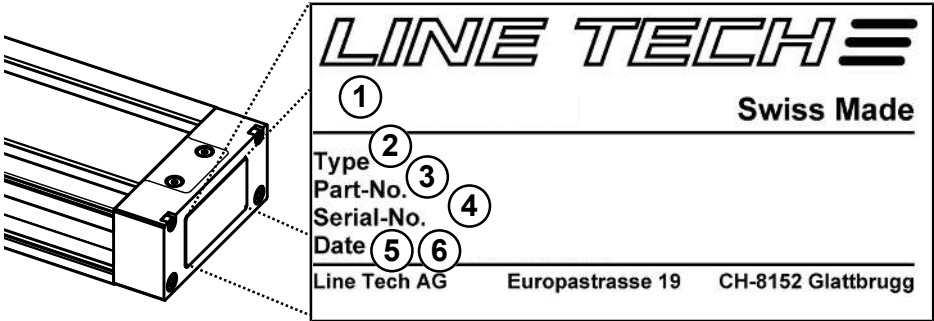

The following information is included on the type plate and makes it easy to identify the module:

- Description (1)
- Type designation (2)
- Part number (3)
- Serial number (4)
- Manufacturing date; calendar week/year (5)
- Repair date (6; if available)



NOTE

If problems occur with the module, provide the manufacturer or sales partner with the information on the type plate.

4 Transport

4.1 Safety



SAFETY INSTRUCTIONS

Working safely while transporting the compact unit!

Carry out all work in compliance with the following safety instructions:

- ▶ Comply with the provisions listed in the *Safety* [▶ 14] chapter for all work performed on/with the compact unit.
- ▶ Observe the instructions and personnel requirements as per the *Personnel requirements* [▶ 16] chapter.
- ▶ Provide suitable forklift trucks or lifting gear for transportation.
- ▶ Wear personal protective equipment (safety shoes, protective gloves and hard hat).



NOTICE

Property damage due to improper transportation!

Improper transportation may result in property damage.

- ▶ Do not expose the parts to be transported to hard shocks during transportation.
- ▶ Make sure there is sufficient free space during transport.
- ▶ Always provide support for compact units longer than 700 mm during transportation.
- ▶ Use caution when lifting and setting down the machine.

4.2 Transport by forklift

Conditions for transportation

Packages that are attached to pallets can be transported with a forklift under the following conditions:

- The forklift must be designed for the weight of the transport items.
- The item to be transported must be securely fastened to the pallet.
- The forklift driver is authorized to do this.

Lifting packages

- a) Drive the forklift with the tines between or under the pallet's beams.
- b) Drive the tines in far enough that they protrude on the opposite side.
- c) Make sure that the pallet cannot tip if the center of gravity is eccentric. Observe the special information about the center of gravity on the packages.
- d) Lift the pallet with the transport unit and begin the transport operation.

4.3 Transport with the crane



WARNING

Danger to life from suspended loads!

Danger from falling or uncontrolled swinging parts.

- ▶ Never stand under suspended loads.
- ▶ Do not attach lifting gear to protruding module parts or to eyelets on attached components. Ensure that the slings are securely fastened.
- ▶ Only use approved lifting gear and slings with sufficient load capacity.
- ▶ Transport may only be carried out by personnel trained for this purpose.

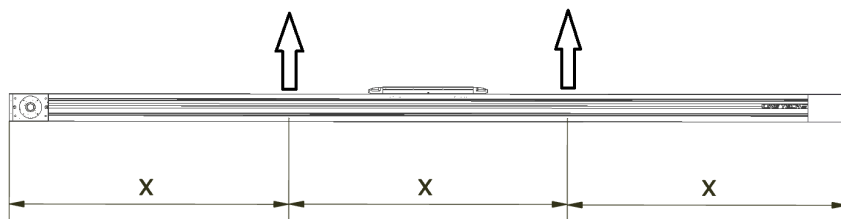

Conditions for transportation

The compact units or packages that are secured to pallets or packed in crates can be lifted and moved with a crane (for compact units or packages that exceed a length of 9 meters, consult the manufacturer).

Ensure that

- the slings are designed for the weight to be lifted.
- the crane operator is authorized to do so.

Lifting compact units or packages

Lift compact units or packages as follows:

- a) Ensure that the carriage is positioned approximately in the center.
- b) Attach compact units or packages.
- c) Attach two lifting straps at equal distances ($\frac{1}{3}$ / $\frac{1}{3}$ / $\frac{1}{3}$) and lift vertically.
- d) Do not choose an angle of attack that is too flat.
- e) Ensure that ropes and straps, etc. are not twisted and that the compact units or packages are securely fastened.
- f) Lift the compact units or packages and begin the transport operation.

4.4 Transport inspection and scope of delivery

Transport inspection

Check that the delivery is complete and that there is no transport damage immediately upon receipt.

If there is any visible external transport damage, proceed as follows:

- Do not accept the delivery or only accept it with reservations.
- Record the extent of the damage on the transport documents or on the carrier's delivery document.
- Submit a complaint.



NOTE

Report any defect as soon as it is detected. Claims for damages can only be made within the valid complaint periods.

Scope of supply

Refer to the delivery document for the scope of delivery. The scope of delivery of the product includes:

- Compact unit as specified in the order confirmation
- Assembly and maintenance instructions
- Additional and special accessories according to the order

4.5 Storage



NOTICE

Property damage due to improper storage!

Improper storage may result in property damage.

- ▶ Always store the compact unit/compact unit parts in compliance with the following conditions.
- ▶ Use caution when lifting and setting down the machine.

If the compact unit is not used for more than two months or is stored before installation, observe the following conditions:

- Make sure that the compact unit is clean. Clean the compact unit if necessary.
- Do not store outdoors.
- Store in a dry location that is free of dust.
- Do not expose to aggressive media.
- Protect from sunlight.
- Avoid mechanical vibrations.
- Store the compact unit in a box that is well-padded.

5 Assembly

5.1 Safety



SAFETY INSTRUCTIONS

Working safely while assembling the compact unit!

Carry out all work in compliance with the following safety instructions:

- ▶ Comply with the provisions listed in the *Safety* [▶ 14] chapter for all work performed on/with the compact unit.
- ▶ All installation work must only be carried out by specially trained personnel (see the *Personnel requirements* [▶ 16] chapter).
- ▶ Work on electrical systems must only be carried out by qualified personnel (see the *Qualifications* [▶ 16] chapter).
- ▶ Wear protective equipment in accordance with local accident prevention regulations for all assembly work.
- ▶ Make sure that there is sufficient space for assembly before starting work.
- ▶ Make sure that the assembly area is tidy and clean! Components and tools that are loosely stacked on top of each other or lying around create a risk of accidents.
- ▶ If components have been removed or adjusted, ensure correct assembly, reinstall all fastening elements and observe the screw tightening torques.
- ▶ Do not stand under suspended loads.
- ▶ Observe the relevant environmental protection instructions. If environmentally hazardous substances are accidentally released into the environment, take appropriate measures immediately. In case of doubt, notify the responsible local authority of the damage.

5.2 Delivery configurations

Compact units with ball screw drive can be supplied in various configurations and with different pre-installed motor mounts.

The following delivery configurations are possible:

Delivery configuration 01 - Free spindle end

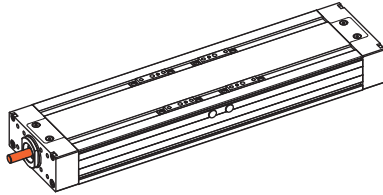

Delivery configuration 02 - With coupling and intermediate flange

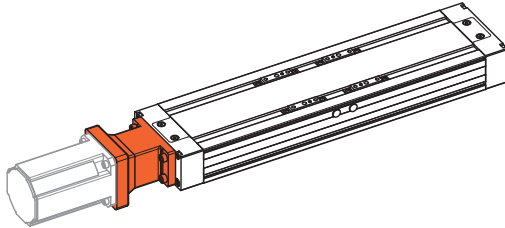

Delivery configuration 04 - Belt drive housing for side motor mounting on the right

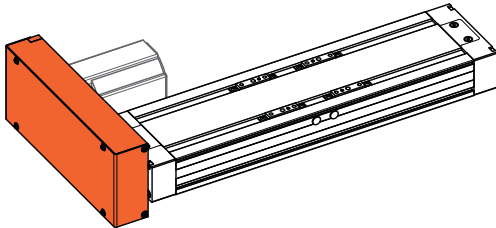

Delivery configuration 05 - Belt drive housing for side motor mounting on the left

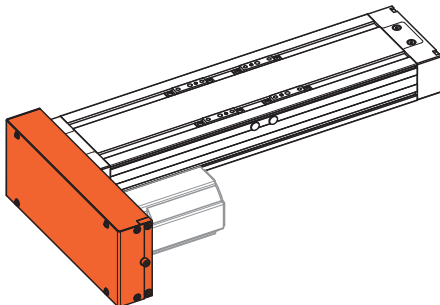

Delivery configuration 06 - Belt drive housing for side motor mounting at the top

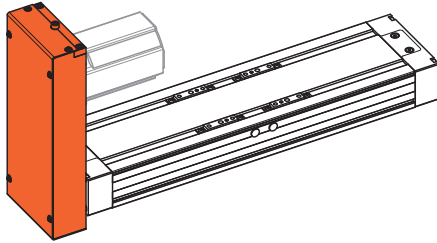

Delivery configuration 07 - Belt drive housing for side motor mounting at the bottom

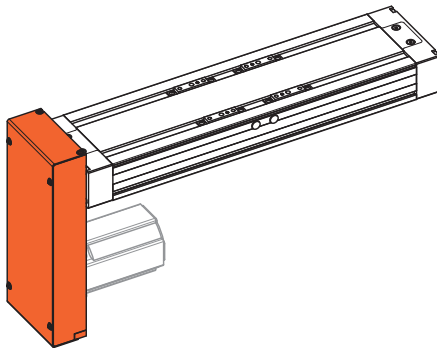

5.3 Permissible deflection with toothed belt drive

Compact units can be installed as cantilevered structures. However, deflection must be taken into consideration, since this limits the possible load.

If the maximum permissible deflection is exceeded, the compact units must be additionally supported.

The maximum permissible deflection is limited by the maximum deflection angle of 5° . If this value is exceeded without support, it will affect the module's service life.

If there are increased requirements for system accuracy, we recommend supporting the compact units along their entire length.

The following diagrams (see the next page) apply to:

- fixed clamping (40 – 50 mm per side)
- 3 – 4 screws per side
- Fixed substructure
- Horizontal or upright installation position

Horizontal installation position:

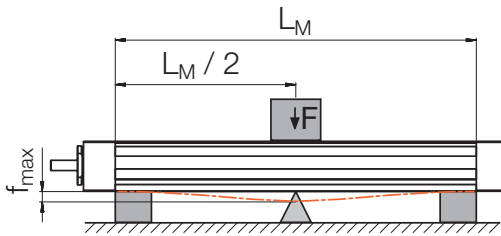

Upright installation position:

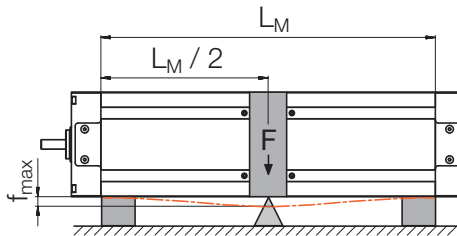

KE1... horizontal

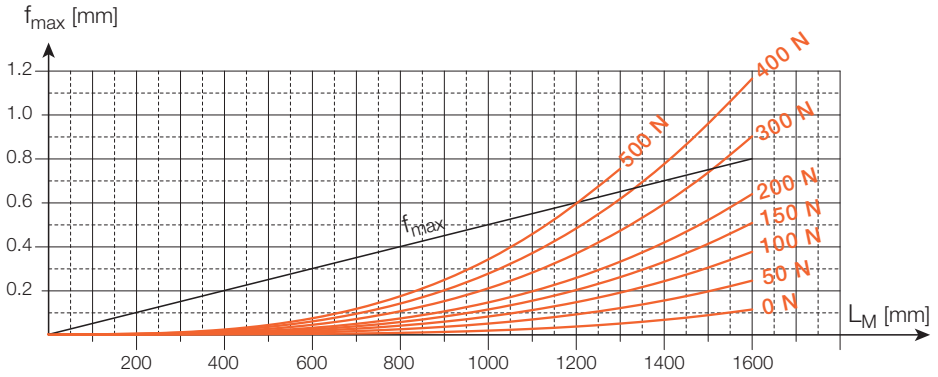

KE1... upright

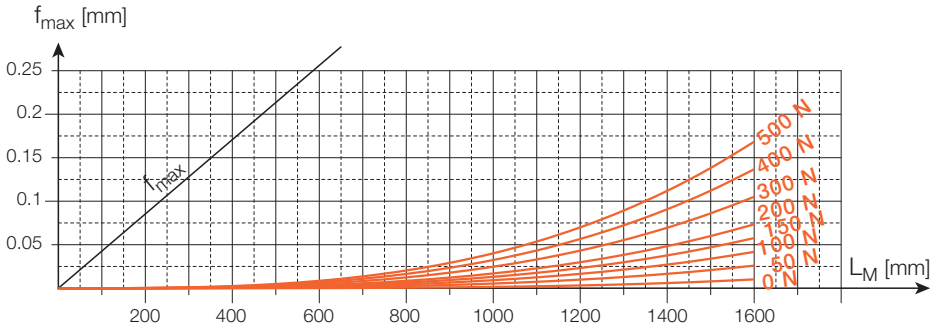

KE2... horizontal

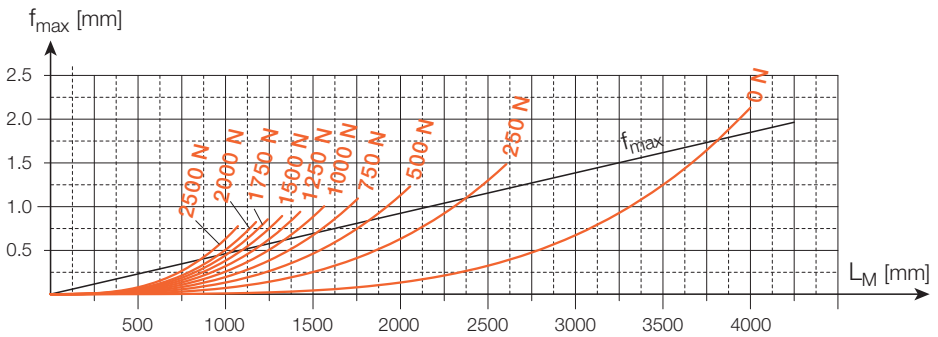

KE2... upright

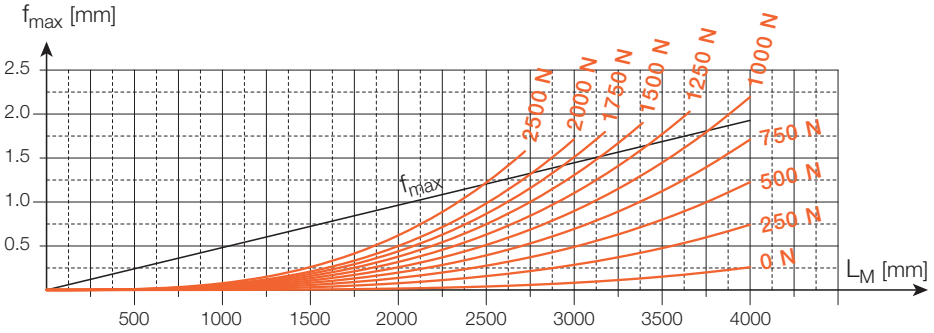

KE3... horizontal

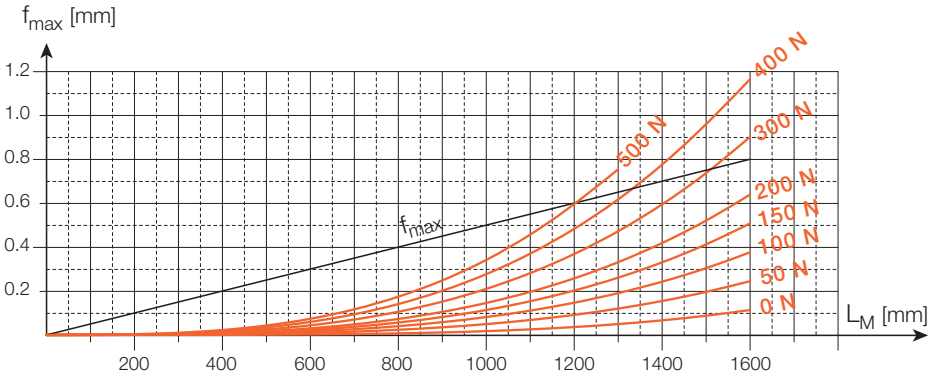

KE3... upright

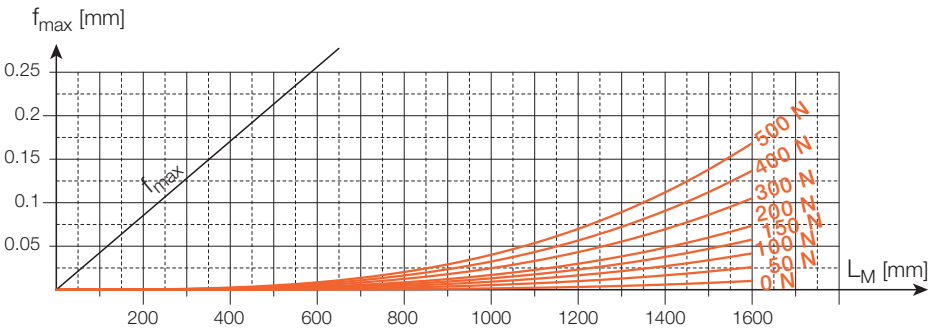

5.4 Attaching the compact unit

5.4.1 General information

Attach the compact units using clamping flanges or sliding blocks.



NOTICE

Property damage due to improper fastening!

If end plates are used as load-bearing elements, the compact unit may be damaged.

- ▶ Only fasten or support the compact unit to the base body and not to the end plates.

5.4.2 Attaching the compact unit using clamping flanges

Overview

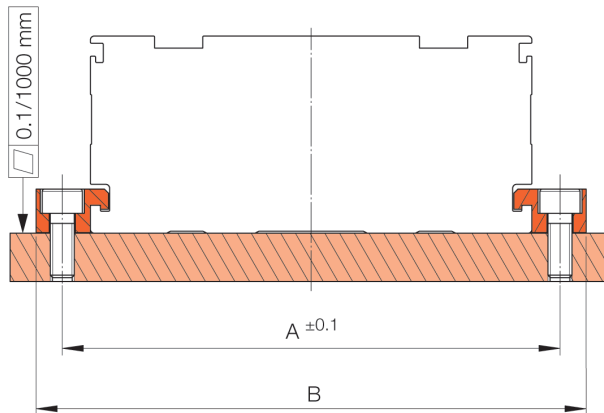

| Nominal size | Dimensions [mm] | |
|--------------|-----------------|-----|
| | A | B |
| KE1... | 102 | 112 |
| KE2... | 126 | 140 |
| KE3... | 161 | 175 |

Assembly options

Use the following number of clamping flanges:

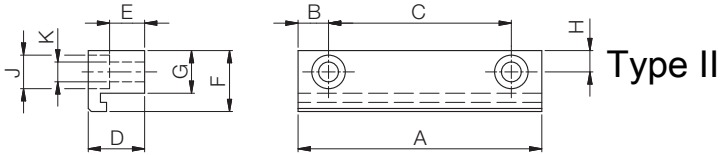

- 4 clamping flanges per meter and side, type I
- 3 clamping flanges per meter and side, type II

The clamps can be ordered from LINE TECH AG according to the following table.

| Nomin- al size | Dimensions [mm] | | | | | | | | | | | Art. No. |
|----------------------|-----------------|----|-----|----|------|-----|------|----|---|------|-------|----------|
| | Type | A | B | C | D | E | F | G | H | J | K | |
| KE1 | I | 35 | 7.5 | 20 | 7.6 | 2.6 | 14.5 | 11 | 5 | Ø 8 | Ø 4.5 | P-54434 |
| | II | 80 | 10 | 20 | | | | | | | | P-54435 |
| KE2/3 | I | 60 | 10 | 40 | 10.5 | 4.5 | 19.5 | 15 | 7 | Ø 11 | Ø 6.5 | P-54179 |
| | II | 80 | | 20 | | | | | | | | P-54181 |

Assembly

- Attach the compact units using clamping flanges.
- Secure screws with Loctite.
- Observe the tightening torques *Tightening torques for screws* [▶ 67].

5.4.3 Attaching the compact unit using clamping flanges

Usage

Sliding blocks with the corresponding groove width can be used to fasten attachments and extensions to the connecting plates (KE...V...).

Sliding block types

The type of sliding block to be used depends on the groove width:

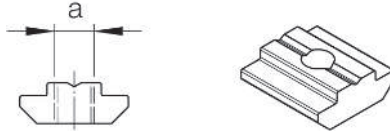

| Dimensions [mm] | | The material |
|-----------------|-------------|-----------------------|
| Groove width | a (thread) | |
| 6 (KE1 / KE2) | M4/M5/M6 | Steel/stainless steel |
| 8 (KE3) | M4/M5/M6/M8 | Steel/stainless steel |

When ordering sliding blocks, please specify the size, material, and connection thread (e.g., NS6 St M5-KE).

Assembly

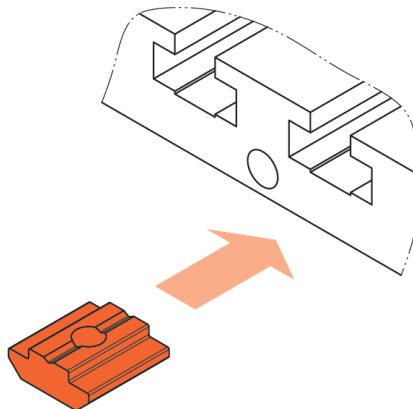

a) Push the sliding blocks into the corresponding groove.

5.5 Assembling limit switches

5.5.1 Limit switch assembly

The limit switches are supplied with loose connection cables (length 2 m) as standard. A version with a connector box with pre-wired cables is also available as an option.

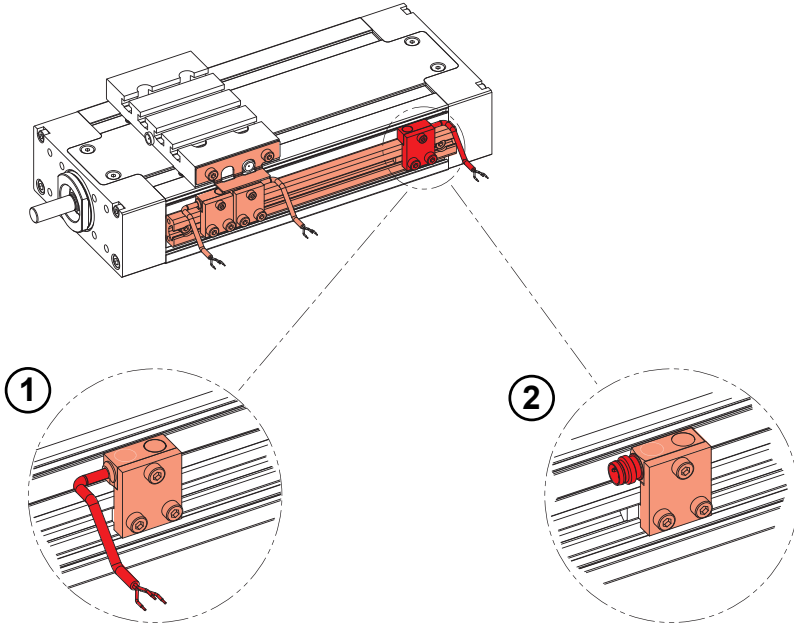

1 Standard:
Version with loose cable end (L = 2 m)
(order code N)

2 Option:
M8 connector
(order code C)



NOTE

Limit switches, mating connectors, and cables are not included in the scope of delivery. They can be purchased ready-made from LINE TECH AG.

5.5.2 Overview of limit switch/reference switch installation

Function

The limit switches are required in combination with a control unit to limit the stroke (to prevent the carriage from overrunning) and determine a reference point for setting the zero point.

The positive and negative limit switches are preset at the factory to a nominal stroke of 0 to +5 mm.

The following inductive limit switches are used as standard:

- PNP normally closed (PNP NC)
- Power supply: 10...30 V DC
- Current consumption without load: < 10 mA
- Load max. 200 mA

Overview

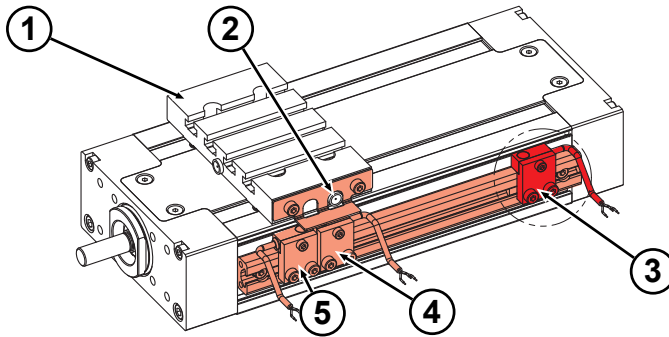

- | | | | |
|---|---|---|------------------|
| 1 | Connecting plate or customer installation | 2 | Switching lug |
| 3 | Positive limit switch (+) | 4 | Reference switch |
| 5 | Negative limit switch (-) | | |

Position reference switch

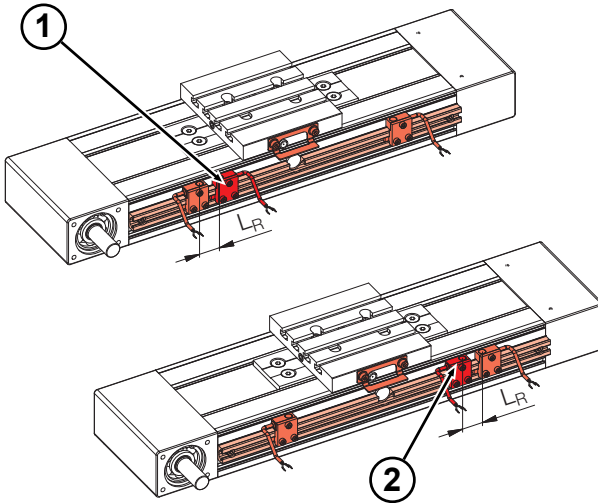

- 1 Reference switch at front (motor side)
- 2 Reference switch at rear (motor side)

Position reference switch (L_R); $L_R = 20\text{ mm}$

5.5.3 Position of the limit switches

Position

Refer to the following figure for the position of the limit switches:

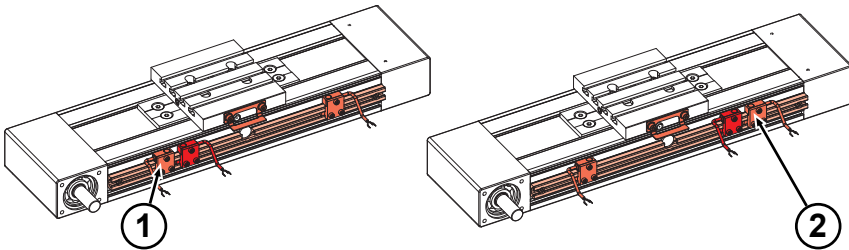

- 1 Left limit switch
- 2 Right limit switch

The reference point can be assigned to the positive (+) or negative (-) limit switch.

Dimensions

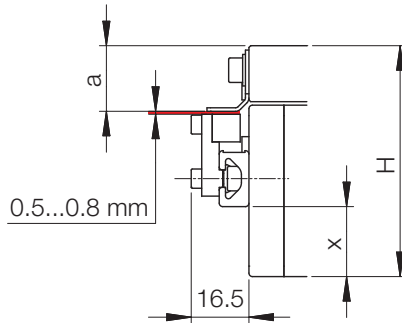

| Size | Dimensions [mm] | | |
|------|-----------------|------|----|
| | x [mm] | a | H |
| KE1 | 3 | 17.5 | 56 |
| KE2 | 13 | 17 | 66 |
| KE3 | 32.5 | 17 | 85 |

Special applications

Special applications often require a separate reference point switch, which is mounted between the positive and negative limit switches. The limit switch that is closer to the motor mounting (limit switch control interface) is referred to as the front limit switch.

Limit switch connection diagram

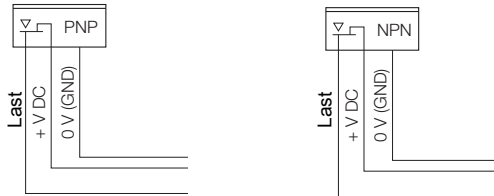

Color code legend

- Load = black (BK)
- +V DC = brown (BN)
- 0 V (GND) = blue (BU)

5.6 Installing the motor and gearbox

5.6.1 General information



⚠ DANGER

Danger due to electric shock!

There is a risk of electric shock on contact with live components.

- ▶ Work on the electrical equipment must only be carried out by qualified electricians.
- ▶ De-energize the linear module before carrying out any work (disconnect the power plug).



NOTE

Observe the information in the manufacturer's instructions regarding the motors and gearboxes to be installed.

5.6.2 Straight with ball screw

Motor mounting

Mount the motor as follows:

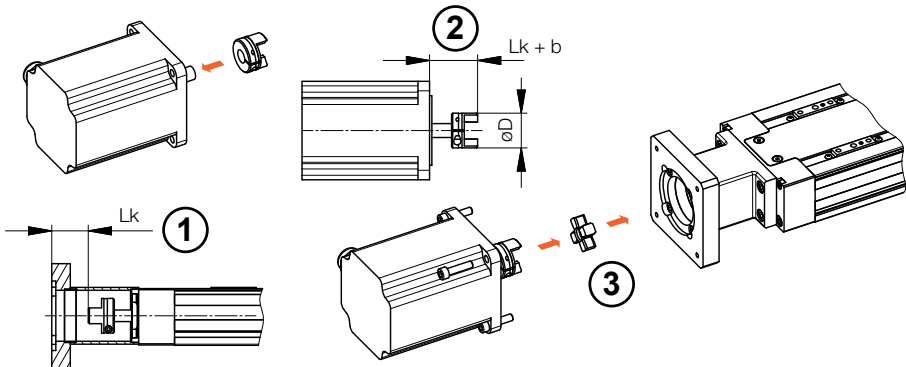

- a) Measure distance L_k on the unit (1).
- b) Attach the clamping hub to the motor mount at a distance of $L_k + b$ (2). Observe the tightening torque of the clamping screw.
- c) Mount the pre-assembled motor with gear rim to the unit (3).

Tightening torques of the clamping screw

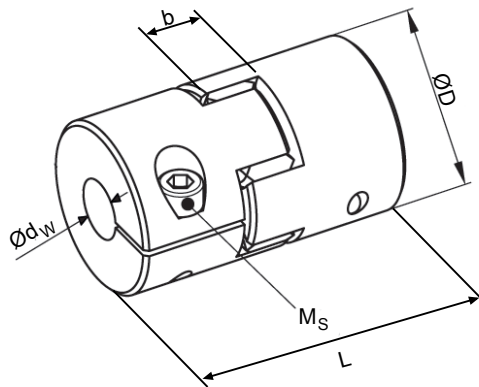

| Size | Dimensions [mm] | | | | Clamping screw tightening torque [Nm] | | Drive torque [Nm] | |
|------|-----------------|-----------------|----|-------------------|---------------------------------------|-------|-------------------|-----------|
| | L | $\varnothing D$ | b | $\varnothing d_w$ | Type | M_s | T_N | T_{max} |
| 12 | 34 | 25 | 11 | ≤ 12 | ISO 4762 (DIN 912) | 1.34 | 5.0 | 18 |
| 14 | 35 | 30 | 10 | ≤ 16 | ISO 4762 (DIN 912) | 1.34 | 6.3 | 25 |
| 19 | 66 | 40 | 12 | ≤ 20 | ISO 4762 (DIN 912) | 10.10 | 17.0 | 34 |
| 19 | 66 | 40 | 12 | ≤ 20 | ISO 7380 | 7.20 | 17.0 | 34 |

Motor attachments and parts list

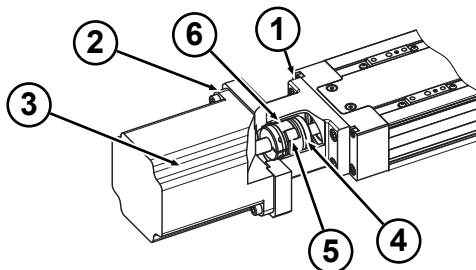

- | | | | |
|---|---------------------|---|----------------------|
| 1 | Intermediate flange | 2 | Motor plate |
| 3 | Motor | 4 | "KE" clamping hub |
| 5 | Gear rim | 6 | "Motor" clamping hub |

5.6.3 Side, with ball screw drive

Motor mounting

Mount the motor as follows:

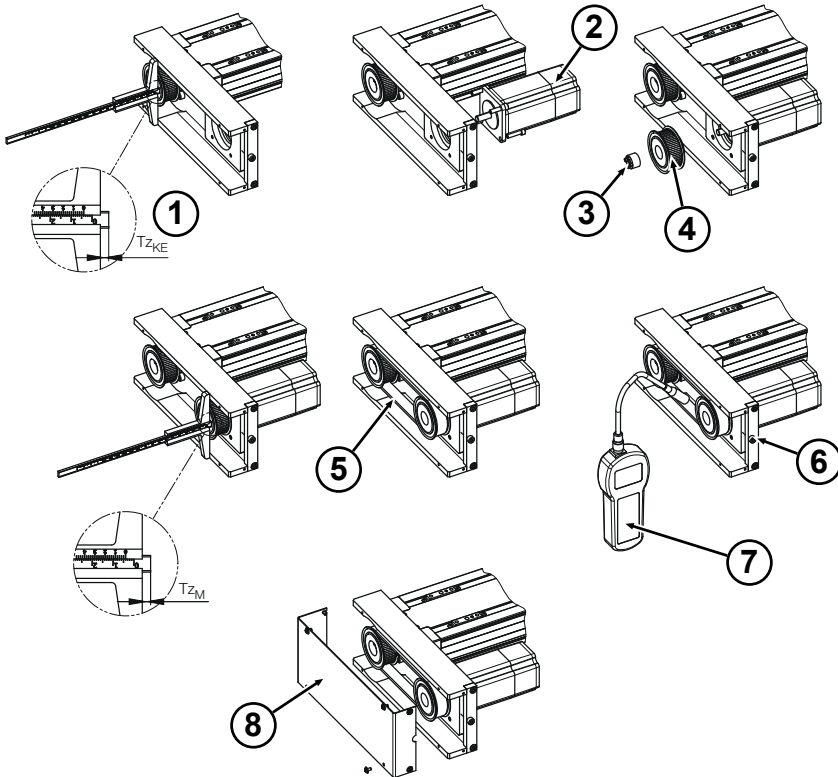

- Measure the assembly depth of the mounted Tz_{KE} toothed pulley on the unit. (1).
- Mount the motor (2) to the belt drive housing using the appropriate screws. Make sure that the screws are only tightened to the extent that the motor and motor plate can still be moved slightly.
- Mount the toothed pulley (4) on the motor side using the clamping set (3) at the same assembly depth ($Tz_{KE} = Tz_M$).
- Insert the toothed belt (5) and tension it using the tensioning screw (6).
- Check the toothed belt tension using a frequency meter (7). Determine the adjustment frequency "f". (Refer to the instructions for the frequency meter used).
- Tighten the motor mounting screws to the specified tightening torques.
- Mount the cover plate (8).

Tightening torques of the clamping screw

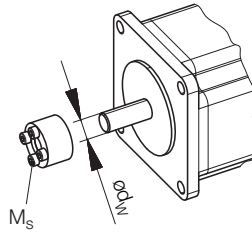

| Motor shaft ødW [mm] | Type ISO 4762 | Tightening torque M _s [Nm] |
|----------------------------|------------------|---|
| ø5...ø12 | M2.5 x 10 | 1.2 |
| ø14, ø15 | M3 x 16 | 2.1 |
| ø16...ø19 | M4 x 20 | 4.9 |
| ø20, ø22 | M5 x 20 | 10.0 |
| ø24...ø32 | M6 x 24 | 17.0 |

Motor attachments and parts list, side with ball screw drive

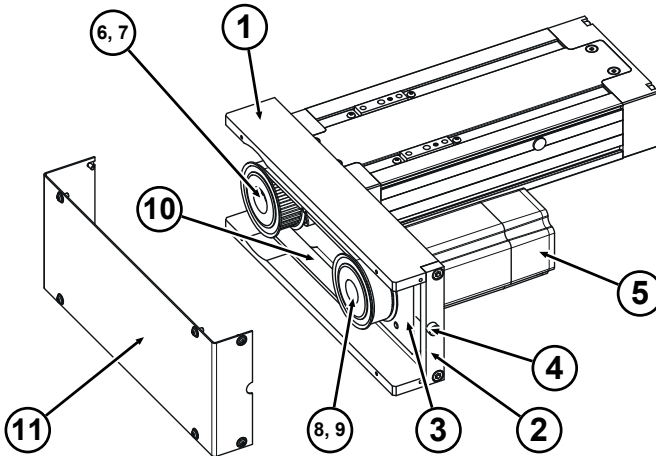

- | | | | |
|----|---------------------------|----|-----------------------------|
| 1 | Belt drive housing | 2 | Belt tensioning plate |
| 3 | Motor plate | 4 | Tensioning screw |
| 5 | Motor | 6 | Compact unit toothed pulley |
| 7 | Compact unit clamping set | 8 | Motor toothed pulley |
| 9 | Motor clamping set | 10 | Toothed belt |
| 11 | Cover plate | | |

5.6.4 Calculation of the preload frequency

The preload frequency of the toothed belt tension can be calculated according to the following specifications:

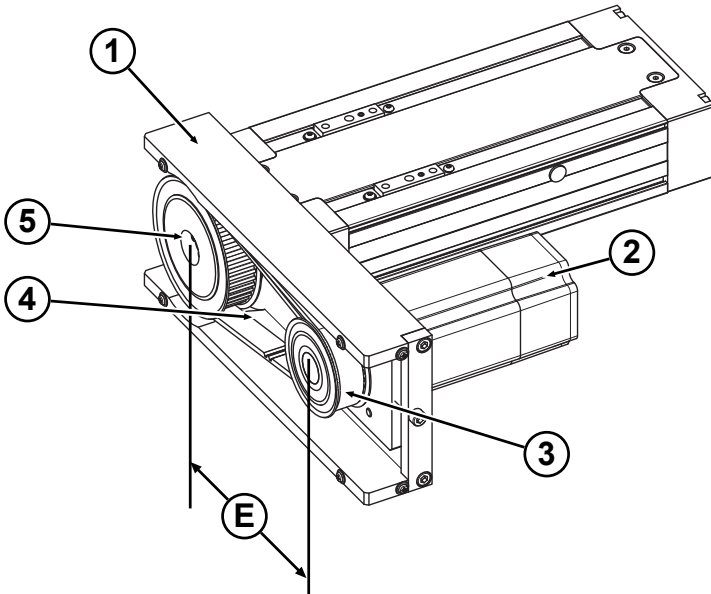

- | | | | |
|---|--|---|-----------------|
| 1 | Belt drive housing | 2 | Motor |
| 3 | Motor toothed pulley PE Number of teeth = z_M | 4 | Toothed belt |
| 5 | Toothed pulley KE Number of teeth = z_{KE} | E | Center distance |

β = Wrap angle [°]

b = Belt width [mm]

E = Center distance [mm]

E_{eff} = Effective center distance [mm]

f = Belt preload frequency [Hz]

F_U = Circumferential force [N]

F_{Uzu} = Permissible preload force [N]

F_V = Preload force [N]

L_F = Free drum length [m]

L_R = Belt length [mm]

M_M = Motor torque [Nm]

m_{spec} = Specific toothed belt weight [kg/m]

n_M = Motor speed [rpm]

P = Power in [kW]

t = Pitch [mm]

v_M = Motor toothed pulley speed [m/s]

z_M = Number of motor teeth [-]

z_{KE} = Number of compact unit teeth [-]

| Nominal size | Reduction ratio | Center distance | Number of teeth | | Belt data | | | | |
|--------------|-----------------|-----------------|-----------------|----|-----------|-------|-------|--------------|---------------------------|
| | | | | | Length | Width | Pitch | Spec. weight | Max. perm. pre load force |
| | | | | | | | | | |
| i | E [mm] | Z_M | Z_{KE} | | | | | | |
| KE1... | 1:1 | 92.5 | 28 | 28 | 325 | 15.0 | 5.0 | 0.065 | 330 |
| | 1:1.5 | 99.4 | 28 | 42 | 375 | 15.0 | 5.0 | 0.065 | 330 |
| | 1:2 | 94.8 | 21 | 42 | 350 | 15.0 | 5.0 | 0.065 | 330 |
| KE2... | 1:1 | 132.5 | 32 | 32 | 425 | 15.0 | 5.0 | 0.065 | 330 |
| | 1:1.5 | 136.9 | 32 | 48 | 475 | 15.0 | 5.0 | 0.065 | 330 |
| | 1:2 | 133.6 | 24 | 48 | 450 | 15.0 | 5.0 | 0.065 | 330 |
| KE3... | 1:1 | 132.5 | 32 | 32 | 425 | 15.0 | 5.0 | 0.065 | 330 |
| | 1:1.5 | 136.9 | 32 | 48 | 475 | 15.0 | 5.0 | 0.065 | 330 |
| | 1:2 | 133.6 | 24 | 48 | 450 | 15.0 | 5.0 | 0.065 | 330 |

1. Wrap angle β

$$\beta = 2 \cdot \arccos \cdot \left[\frac{t \cdot (z_{KE} - z_M)}{2 \cdot \pi \cdot E} \right] [^\circ]$$

2. Effective center distance E_{eff}

$$E_{eff} = \frac{1}{4} \cdot \left[L_R - \frac{t}{2} \cdot (z_{KE} + z_M) + \sqrt{\left[L_R - \frac{t}{2} \cdot (z_{KE} + z_M) \right]^2 - 2 \cdot \left[\frac{t}{\pi} \cdot (z_{KE} - z_M) \right]^2} \right] [\text{mm}]$$

3. Power P

$$P = \frac{M_M \cdot n_M}{9.55 \cdot 10^3} [\text{kW}]$$

4. Motor toothed pulley speed v_M

$$v_M = \frac{n_M \cdot z_M \cdot t}{60 \cdot 10^3} [\text{m/s}]$$

5. Circumferential force F_U

$$F_U = \frac{P \cdot 10^3}{v_M} [\text{m/s}]$$

6. Inspection F_U

$$F_U \leq F_{Uzul}$$

7. Preload force F_V

$$F_V = F_U \cdot \sin \frac{\beta}{2} \cdot 0.61 \quad [\text{N}]$$

8. Free drum length L_F

$$L_F = \sqrt{E_{\text{eff}}^2 - \frac{(z_{KE} - z_M)^2}{4}} / 1000 \quad [\text{m}]$$

9. Belt preload frequency f

$$f = \sqrt{\frac{F_U}{4 \cdot m \cdot L_F^2}} \quad [\text{Hz}] \quad -0\% / +10\%$$

5.6.5 Connecting plates

Connecting plates for compact units

Aluminum connecting plates for LINE-TECH compact units expand the mounting options. They also allow for position-independent lubrication, since there are enough lubrication points on the connecting plates.

Connecting plate for KE with 1 carriages

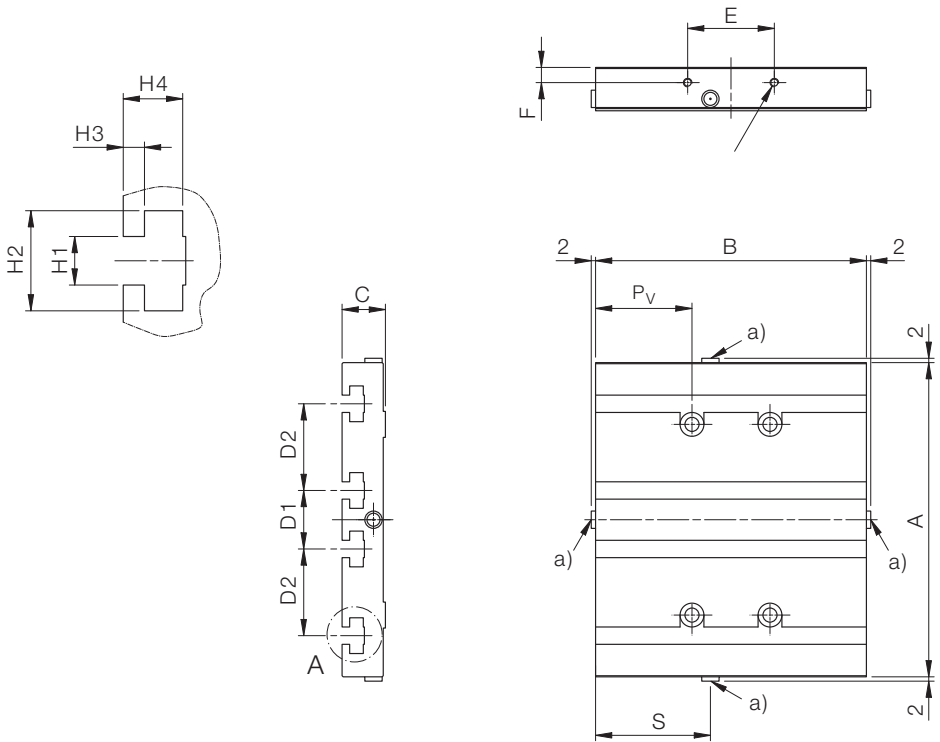

| Nomin- al size | Dimensions [mm] | | | | | | | | | | | | | Weight [kg] | Art. no. |
|----------------------|-----------------|-----|----|----|----|----|-----|----|------|-----|-----|----------------|------|----------------|-------------|
| | A | B | C | D1 | D2 | E | F | H1 | H2 | H3 | H4 | P _v | S | | |
| KE1.2... | 90 | 60 | 16 | 20 | 20 | 30 | 8.5 | 6 | 12.0 | 3.5 | 7.7 | 16.5 | 37.0 | 0.183 | G-10921 |
| KE2.2... | 110 | 60 | 16 | 20 | 20 | 40 | 7 | 6 | 12.0 | 3.5 | 7.7 | 15 | 37.5 | 0.213 | G-10923 |
| KE3.2... | 145 | 125 | 20 | 27 | 40 | 40 | 7 | 8 | 16.5 | 3.5 | 9.8 | 44.5 | 53.0 | 0.727 | G-10925 |

Connecting plate for KE with 2 carriages

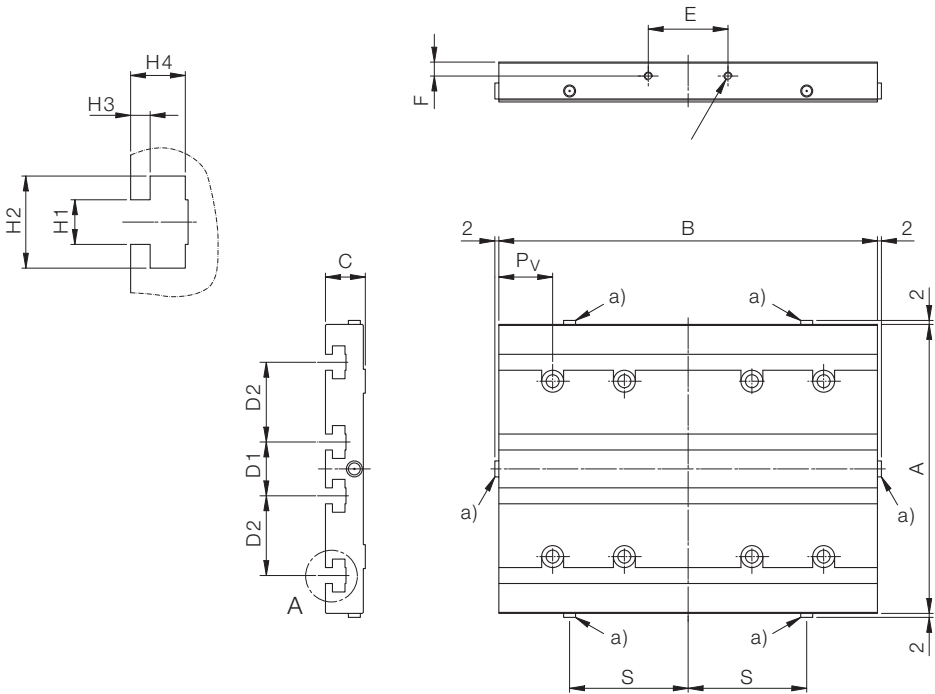

| Nominal size | Dimensions [mm] | | | | | | | | | | | | | | Weight [kg] | Art. no. |
|--------------|-----------------|-----|----|----|----|----|-----|----|------|-----|-----|------|------|-------|-------------|----------|
| | A | B | C | D1 | D2 | E | F | H1 | H2 | H3 | H4 | Pv | S | | | |
| KE1.4... | 90 | 125 | 16 | 20 | 20 | 30 | 8.5 | 6 | 12.0 | 3.5 | 7.7 | 16.5 | 15.0 | 0.385 | G-10922 | |
| KE2.4... | 110 | 155 | 16 | 20 | 20 | 40 | 7 | 6 | 12.0 | 3.5 | 7.7 | 20 | 35.0 | 0.565 | G-10924 | |
| KE3.4... | 145 | 190 | 20 | 27 | 40 | 40 | 7 | 8 | 16.5 | 3.5 | 9.8 | 27 | 59.0 | 1,100 | G-10926 | |

Assembling the connecting plates

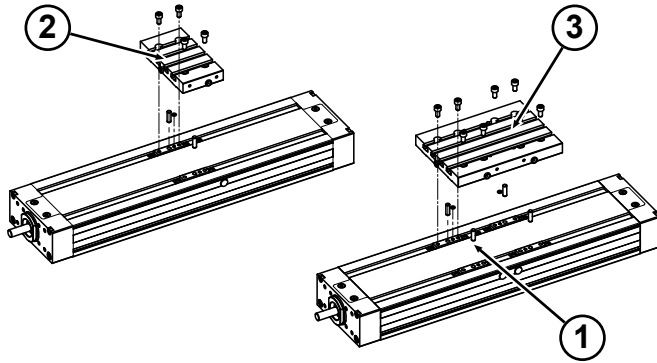

- 1 Threaded pin
- 2 Connecting plate for a carriage
- 3 Connecting plate for two carriages

LINE TECH AG offers various standard connecting plates (2 and 3) on an order-specific basis. The connecting plates can be retrofitted at any time.

a) When assembling, make sure that the threaded pins (1) are removed.

Custom connecting plates

Custom connecting or mounting plates can also be used. In this case, observe the following dimensions:

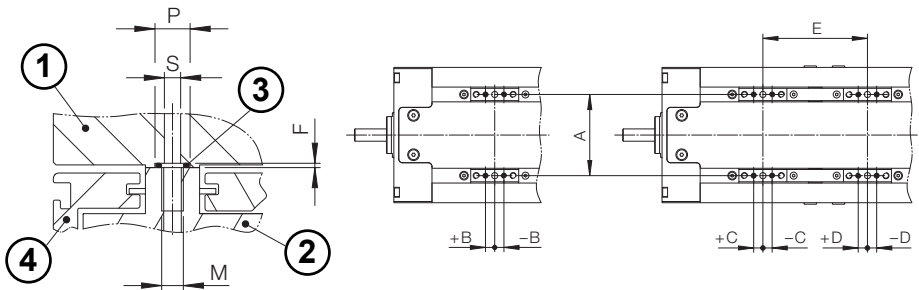

- 1 Customer-side installation
- 2 Carriage
- 3 O-ring
- 4 Base profile

| Dimensions [mm] | | | | | | | | | | |
|-----------------|----|------|------|-------|-----|-----|----|-------|-----|--------|
| Size | A | B | C | D | E | F | M | P | S | O-ring |
| KE1 | 54 | -6.8 | -6.8 | 6.8 | 65 | 0.8 | M3 | ø 6.5 | ø 3 | ø 4x1 |
| KE2 | 66 | -7.5 | -7.5 | 7.5 | 85 | 0.8 | M4 | ø 6.5 | ø 3 | ø 4x1 |
| KE3 | 88 | 11.5 | 11.5 | -11.5 | 100 | 0.8 | M5 | ø 6.5 | ø 3 | ø 4x1 |

5.6.6 Cross table

Cross table for compact units

LINE TECH compact units are also available as dual-axis units (cross tables). A total of four mounting types are possible.

Assembly types

Cross tables of mounting types AC and AD are mounted using clamping flanges. The lower unit must always be designed with two slides and a connecting plate (KE...4...V...). A special intermediate plate is additionally mounted on the upper units for mounting types BC and BD. The individual compact units must be ordered separately.

Montageart AC

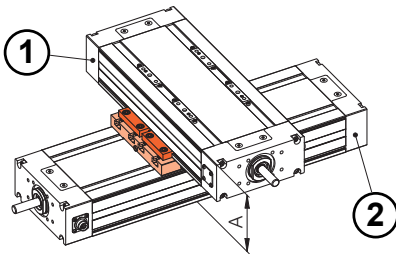

Montageart BC

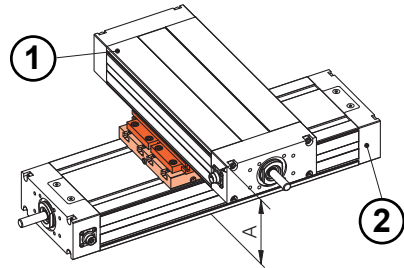

Montageart AD

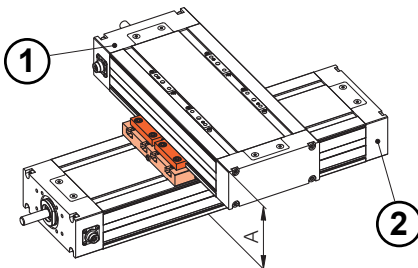

Montageart BD

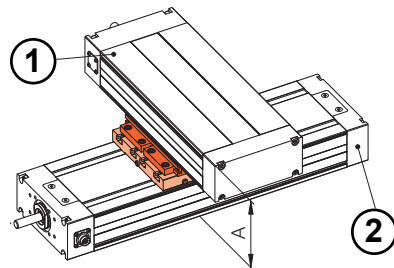

1 Upper unit
(KE...2... or KE...4...)

2 Lower unit
(KE...4...V...)

Dimensions

| Dimension A [mm] | Upper unit | | | | | |
|------------------|-------------|------------|--------|--------------|--------|--------------|
| | KE1... | | KE2... | | KE3... | |
| Assembly type | A.. | B.. | A.. | B.. | A.. | B.. |
| Lower unit | KE1.4...V.. | 96 | 112 | Not possible | | |
| | KE2.4...V.. | 106 | 122 | 116 | 132 | Not possible |
| | KE3.4...V.. | On request | | 135 | 151 | 150 169 |

Cross table assembly types A... and B...

Cross table assembly type A

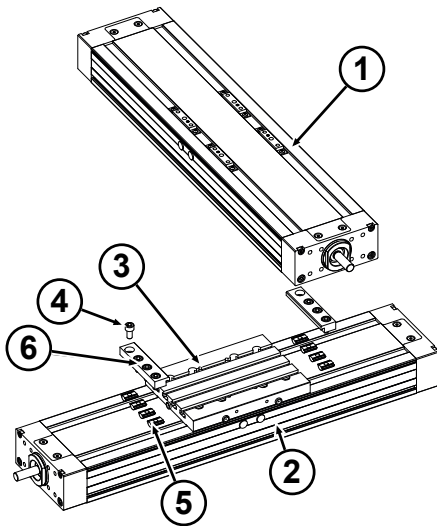

Cross table assembly type B

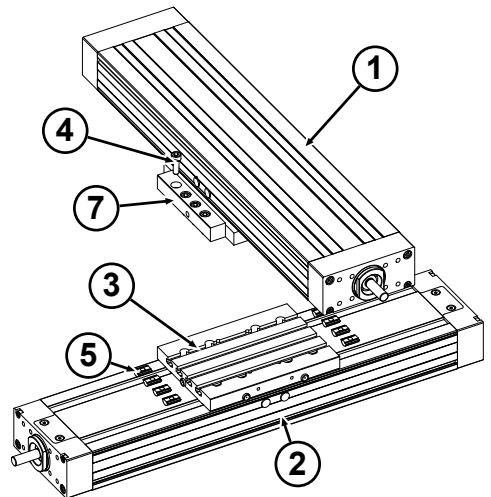

| | Assembly type A | Assembly type B |
|---|---------------------------------------|--------------------------|
| 1 | Upper unit | |
| 2 | Lower unit | |
| 3 | Connecting plate or mounting plate | |
| 4 | Screw ISO 4762 (M4, M5 or M6) | |
| 5 | Sliding blocks (NS6..-KE or NS8..-KE) | |
| 6 | Clamping flanges (e.g. type 2) | - |
| 7 | - | Special connecting plate |

6 Operation

6.1 Safety



SAFETY INSTRUCTIONS

Working safely while operating the compact unit!

All work must be carried out in compliance with the safety instructions listed below:

- ▶ Comply with the provisions listed in the *Safety* [▶ 14] chapter for all work performed on/with the compact unit.
- ▶ Wear protective equipment in accordance with the accident prevention regulations at the operating site.
- ▶ Carry out all operating steps in accordance with the information in these assembly instructions.
- ▶ Before starting work, make sure that all covers and safety devices are installed and functioning properly.
- ▶ Never disable safety devices during operation.
- ▶ Keep the work area clean and tidy! Components and tools that are loosely stacked on top of each other or lying around create a risk of accidents.

6.2 Operating conditions

Normal operating conditions

Normal operating conditions

Ambient temperature 10°...80 °C

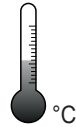

Travel speed See *Permissible speeds* [▶ 67]

Load See *Technical data of ball screw drive* [▶ 66]

Minimum stroke

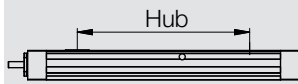

| Type | Minimum stroke |
|------|----------------|
| KE1 | ≥ 35 mm |
| KE2 | ≥ 45 mm |
| KE3 | ≥ 55 mm |

Special operating conditions

For applications in special operating conditions, such as moisture, dirt, dust (fiberglass and wood), aggressive atmospheres, extreme climatic conditions and/or strong temperature fluctuations, short strokes and others, contact LINE TECH AG before commissioning.

7 Maintenance

7.1 Safety



SAFETY INSTRUCTIONS

Working safely while maintaining the compact unit!

Carry out all work in compliance with the following safety instructions:

- ▶ Comply with the provisions listed in the *Safety* [▶ 14] chapter for all work performed on/with the compact unit.
- ▶ All maintenance work must only be carried out by specially trained personnel (see the *Personnel requirements* [▶ 16] chapter).
- ▶ Work on electrical systems must only be carried out by qualified electricians (see the *Qualifications* [▶ 16] chapter).
- ▶ Wear protective equipment in accordance with local accident prevention regulations for all maintenance work.
- ▶ Before starting work, switch off the electrical supply and secure it against being switched on again.
- ▶ Make sure that there is sufficient space for assembly before starting work.
- ▶ Make sure that the assembly area is tidy and clean! Components and tools that are loosely stacked on top of each other or lying around create a risk of accidents.
- ▶ If components have been removed or adjusted, ensure correct assembly, reinstall all fastening elements and observe the screw tightening torques.
- ▶ Observe the specified maintenance intervals.
- ▶ Observe the relevant environmental protection instructions.

7.2 Repairs



NOTE

Repairs to the compact unit are not considered maintenance work. They must only be carried out by trained specialist personnel or the manufacturer's service personnel.

7.3 Maintenance intervals

7.3.1 Notes

Carrying out

- the maintenance work prescribed on the following pages and
- of the maintenance work on purchased components in accordance with the relevant documentation

is required to ensure safe and smooth operation of the compact unit.

The specified maintenance intervals are based on our many years of experience and knowledge. If excessive wear of wear parts is detected or if faults occur more frequently, the operator must shorten the time between two maintenance procedures in an appropriate manner.

Keep a maintenance log to verify that the prescribed maintenance work has been performed.



NOTE

Verification that the required maintenance work has been carried out is a mandatory requirement for claiming any warranty services.

Contact (See reverse side) the manufacturer if there are any doubts.

7.3.2 Maintenance schedule

| Interval | Maintenance work | Description | Personnel |
|----------------|---|--|----------------------|
| Daily | Check the compact unit for externally visible damage. | <i>Checking the compact unit for externally visible damage</i> [▶ 56] | Specialist personnel |
| Every 3 months | Lubricate compact unit | <i>Lubricating the compact unit</i> [▶ 57] | Specialist personnel |
| as required | Tension the belt | | Specialist personnel |

7.4 Maintenance work

7.4.1 Checking the compact unit for externally visible damage

Daily or before each use

- a) Checking the compact unit for externally visible damage and defects.
- b) Visually check that externally attached fasteners, electrical cables and plug connections are in perfect working order.

If changes occur that put the safety of personnel and systems at risk, immediately shut down the compact unit.

7.4.2 Lubricating the compact unit

Lubricants

The linear modules must only be lubricated with grease.

LINE TECH AG carries out the initial greasing procedure. The bearings used are generally maintenance-free and do not need to be relubricated under normal conditions.

LINE TECH AG recommends MICROLUBE GBU-Y 131 as the standard grease. When using other greases (third-party products), first check compatibility with the standard grease. Observe the safety data sheet.

For special operating conditions, please consult us regarding lubricant quantities. The values and information on lubricant quantities in the following table correspond to use under normal operating conditions.

| Type | KGT d x p (mm) | Grease | Grease relubrication quantities | |
|------|----------------------|----------------------------------|---------------------------------|-------------------------------|
| | | | Carriage A (cm ³) | Carriage B (cm ³) |
| KE1 | 12 x 5 | Klüber MICROLUBE GBU-Y 131 | 0.7 | 0.4 |
| | 12 x 10 | | 0.7 | |
| KE2 | 16 x 5 | | 1.6 | 1.0 |
| | 16 x 10 | | 1.8 | |
| | 16 x 16 | 1.9 | | |
| KE3 | 20 x 5 | 2.5 | 1.5 | |
| | 20 x 10 | 2.9 | | |
| | 20 x 20 | 3.2 | | |

There are grease nipples on both sides of the carriage parts. It is sufficient to press in the grease from just one side.

Relubricate the guides and ball screw according to the following table, depending on which value is reached first:

| Type | KGT d x p (mm) | Operating interval (h) | Interval (months) | Running interval (km) |
|------|----------------------|---------------------------|-------------------|--------------------------|
| KE1 | 12 x 5 | 500 | 3 - 6 | 250 |
| | 12 x 10 | | | 500 |
| KE2 | 16 x 5 | 500 | 3 - 6 | 250 |
| | 16 x 10 | | | 500 |
| | 16 x 16 | | | 800 |
| KE3 | 20 x 5 | 500 | 3 - 6 | 250 |
| | 20 x 10 | | | 500 |
| | 20 x 20 | | | 1000 |

Lubrication (procedure)

Lubricate the compact unit as follows:

- Lubricate the table part(s).
- When lubricating with a hand press, calculate the amount of grease per stroke.
- After lubricating, remove excess grease with a clean cloth.

Lubrication points

LINE TECH compact units KE..Z.. are designed so that lubrication is only required at one point. The following lubrication options are available:

- Lubrication nipples according to DIN 3405; the cover caps must be removed for lubrication. Lubrication positions according to the sketches below.
- Connection according to interface for customer installation, page 27; the lubrication positions are stroke-independent.
- Lubrication nipple according to DIN 3405; the lubrication positions are stroke-independent.
- Connection thread M8x1 (optional lubrication option).

To press in the lubricant, we recommend using the grease gun with item no.: ZPE.FETTPRESSE.04

KE...2N...

Guide carriage and ball screw drive

1)

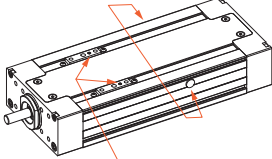

Guide carriage and ball screw c

2)

KE...2V...

Guide carriage and ball screw drive

3)

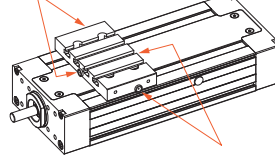

Guide carriage and ball screw c

2)

KE...4N...

Guide carriage and ball screw

Guide carriage and ball screw drive

1)

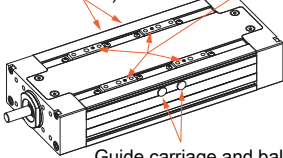

Guide carriage and ball screw

1)

KE...4V...

Guide carriage and ball screw drive

3)

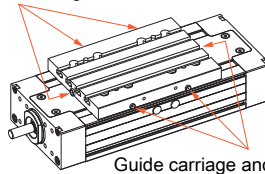

Guide carriage and ball screw

3)

Lubrication through the base profile

The compact unit can be maintained via two lubrication holes. Since the unit has a central lubrication system, it only needs to be lubricated from one side (A or B). The carriage must be in the specified position for lubrication through the base profile (see table). The lubrication positions are shown in the following figures:

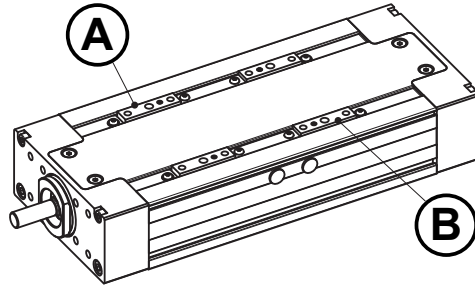

| Stroke position (mm) | KE design | | | | | |
|----------------------|------------|------------|------------|------------|------------|-----------------|
| | KE1.2... | KE1.4... | KE2.2... | KE2.4... | KE3.2... | KE3.4... |
| A: first carriage | Stroke / 2 | Stroke / 2 | Stroke / 2 | Stroke / 2 | Stroke / 2 | Stroke / 2 |
| B: second carriage | - | Stroke / 2 | - | Stroke / 2 | - | Stroke / 2 - 10 |

Separate lubrication unit

LINE TECH compact units can also be purchased with a separate lubrication unit. In the case of a separate lubrication unit, three lubrication points must be lubricated to ensure that all components are adequately supplied with grease.



NOTE

In this case, please refer to the separate customer drawings.

7.5 Measures after completing the maintenance work

After completing the maintenance work and before switching the system on, carry out the following steps:

- a) Check that all previously loosened screw connections are tight.
- b) Check that all previously removed protective devices and covers have been properly reinstalled. Clean the work area and remove any substances that may have leaked, e.g., liquids, processing material or similar.
- c) Make sure that all tools, materials and other equipment that were used have been removed from the work area.
- d) Make sure that all safety equipment is in perfect working order.



DANGER

Danger to life due to premature reactivation!

There is a risk of injury to personnel located in or reaching into the danger zone if the device is switched on again.

- ▶ Before switching the system back on, make sure that there are no personnel in the danger zone or reaching into the danger zone.

8 Faults

8.1 Safety



SAFETY INSTRUCTIONS

Work safely during troubleshooting!

Carry out all work in compliance with the following safety instructions:

- ▶ Comply with the provisions listed in the *Safety* [▶ 14] chapter for all work performed on/with the compact unit.
- ▶ All troubleshooting work must only be carried out by specially trained personnel (see the *Personnel requirements* [▶ 16] chapter).
- ▶ Work on electrical systems must only be carried out by qualified personnel (see the *Qualifications* [▶ 16] chapter).
- ▶ Wear protective equipment in accordance with local accident prevention regulations for all troubleshooting work.
- ▶ Before starting work, switch off the electrical supply and secure it against being switched on again.
- ▶ Make sure that there is sufficient space for assembly before starting work.
- ▶ Make sure that the assembly area is tidy and clean! Components and tools that are loosely stacked on top of each other or lying around create a risk of accidents.
- ▶ If components have been removed or adjusted, ensure correct assembly, reinstall all fastening elements and observe the screw tightening torques.
- ▶ Observe the relevant environmental protection instructions.

8.2 Behavior if a fault represents a hazard

In general, the following applies:

- In case of faults that pose an immediate danger to people or property, switch off the machine immediately.
- Determine the cause of the fault and notify the person responsible at the operating site of the fault.
- If it is necessary to enter danger zones or reach into danger zones during troubleshooting work, secure the machine against being switched on again.
- Have the fault repaired by authorized qualified personnel.

8.3 Possible faults

Possible faults can be indicated by the following:

- Unusual noises
- Sluggish running
- Inaccuracies



NOTE

Contact LINE TECH AG service for troubleshooting (See reverse side) .

8.4 Measures after completing the troubleshooting work

After completing the troubleshooting work and before switching the machine back on, implement the following measures:

- a) Tighten all previously loosened screw connections.
- b) Make sure that any protective devices and covers that were previously removed are properly refitted.
- c) Make sure that all tools and work materials that were used have been removed from the work area.
- d) Clean the work area and remove any spilled substances, such as liquids, processing materials, or similar and dispose of them in an environmentally-friendly manner.
- e) Make sure that all safety equipment is properly installed and functional.



⚠ DANGER

Danger to life due to premature reactivation!

There is a risk of injury to personnel located in or reaching into the danger zone if the device is switched on again.

- ▶ Before switching the system back on, make sure that there are no personnel in the danger zone or reaching into the danger zone.

9 Disassembly and disposal

9.1 Safety



SAFETY INSTRUCTIONS

Working safely when disassembling and disposing of the machine!

All work must be carried out in compliance with the safety instructions listed below:

- ▶ Comply with the provisions listed in the *Safety* [▶ 14] chapter for all work performed on/with the compact unit.
- ▶ The disassembly work must only be carried out by specially trained personnel (see the *Personnel requirements* [▶ 16] chapter).
- ▶ Work on electrical systems must only be carried out by qualified electricians (see the *Qualifications* [▶ 16] chapter).
- ▶ Wear protective equipment in accordance with local accident prevention regulations for all disassembly and disposal work.
- ▶ Before starting disassembly, switch off the electrical supply and permanently disconnect it.
- ▶ Make sure there is sufficient space before starting work.
- ▶ Make sure that the work area is tidy and clean. Components and tools that are loosely stacked on top of each other or lying around create a risk of accidents. Be careful when handling exposed components that have sharp edges.
- ▶ Disassemble components correctly. Note the high dead weight of some components. Use lifting equipment if necessary. Secure components so that they do not fall or fall over.
- ▶ Incorrect handling of environmentally hazardous substances, especially incorrect disposal, can cause considerable damage to the environment. If environmentally hazardous substances are accidentally released into the environment, immediately take measures and notify the responsible local authority of the damage.

9.2 Decommissioning and disassembly

To decommission the compact unit:

- a) Switch off the power supply to the entire system and disconnect it from the power supply.
- b) If necessary, disconnect the pneumatic connections.

- c) Disassemble the compact unit.
- d) Store the compact unit (see chapter *Storage* [▶ 26]) or
- e) disassemble the compact unit into assemblies in compliance with the applicable local environmental protection regulations.

9.3 Disposal



NOTICE

Environmental damage in case of incorrect disposal!

Lubricants and other auxiliary materials are subject to hazardous waste treatment and must only be disposed of by authorized specialist companies! Have disassembled components recycled:

- ▶ Scrap metals.
- ▶ Have plastic elements recycled.
- ▶ Sort the remaining components according to their material properties and dispose of them separately. The local authorities or specialist disposal companies can provide information regarding environmentally friendly disposal.

Pretreat and dispose of components according to the following table:

| Components | Pretreatment | Disposal |
|-----------------------|-----------------|-----------------------|
| Mechanical components | Clean | Scrap |
| Greases | Strip, clean | See safety data sheet |
| Oils | Drain, pump out | See safety data sheet |

10 Technical data

10.1 General technical data

| LM | Travel speed | | Areas of inertia | | Max. stroke ⁶⁾ | Cover strip | Feed and friction force | Moving mass |
|--------------|--------------|-------------------------------|------------------------|--------------------------|---------------------------|-------------|-------------------------|-------------|
| | Type | Linear guide V_{\max} [m/s] | Drive V_{\max} [m/s] | I_y [cm ⁴] | | | | |
| KE1.2...R... | 3.0 | 2) | 11.5 | 95.0 | 1315 | Without | 8.00 | 0.370 |
| | | | | | | With | 12.00 | |
| KE1.4...R... | 3.0 | 2) | 11.8 | 95.0 | 1250 | Without | 12.00 | 0.680 |
| | | | | | | With | 16.00 | |
| KE2.2...R... | 5.0 | 2) | 29.4 | 242.5 | 1375 | Without | 10.00 | 0.790 |
| | | | | | | With | 15.00 | |
| KE2.4...R... | 5.0 | 2) | 29.4 | 242.5 | 1290 | Without | 15.00 | 1,370 |
| | | | | | | With | 20.00 | |
| KE3.2...R... | 5.0 | 2) | 93.3 | 746.0 | 1850 | Without | 15.00 | 1,460 |
| | | | | | | With | 20.00 | |
| KE3.4...R... | 5.0 | 2) | 93.3 | 746.0 | 1750 | Without | 20.00 | 2,470 |
| | | | | | | With | 25.00 | |

²⁾For spindle drives, this depends on the speed characteristic value or the spindle length and the corresponding critical speed.

10.2 Technical data of ball screw drive

| LM | KGT | Axial load rating | | Positioning accuracy | Repeat ability | Acceleration | Axial play | | No load torque |
|----------------|---------------|-----------------------|-------------------------|----------------------|--|--|------------|---------------|----------------|
| | | C ₀ | C _{dyn} | | | | Type | Axial play | |
| Size | d x p [mm] | C ₀ [N] | C _{dyn} [N] | [μ /mm] | [mm] | a _{max} [μ /s ²] | | [mm] | [Nm] |
| KE1... R... | 12 x 5 | 3333 | 3099 | 52/300 | < 0.03 ¹⁾ < 0.01 ¹⁾ | 10.0 | R V | < 0.02 --- | 0.020 0.090 |
| | 12 x 10 | 3333 | 3099 | 52/300 | < 0.03 ¹⁾ < 0.01 ¹⁾ | 10.0 | R V | < 0.02 --- | 0.045 0.180 |
| KE2... R... | 16 x 5 | 4551 | 4327 | 52/300 | < 0.03 ¹⁾ < 0.01 ¹⁾ | 10.0 | R V | < 0.02 --- | 0.030 0.100 |
| | 16 x 10 | 4551 | 4327 | 52/300 | < 0.03 ¹⁾ < 0.01 ¹⁾ | 10.0 | R V | < 0.02 --- | 0.060 0.200 |
| | 16 x 16 | 4551 | 4327 | 52/300 | < 0.03 ¹⁾ < 0.01 ¹⁾ | 10.0 | R V | < 0.02 --- | 0.120 0.320 |
| KE3... R... | 20 x 5 | 5705 | 4912 | 52/300 | < 0.03 ¹⁾ < 0.01 ¹⁾ | 10.0 | R V | < 0.02 --- | 0.050 0.120 |
| | 20 x 10 | 5705 | 4912 | 52/300 | < 0.03 ¹⁾ < 0.01 ¹⁾ | 10.0 | R V | < 0.02 --- | 0.100 0.250 |
| | 20 x 20 | 5705 | 4912 | 52/300 | < 0.03 ¹⁾ < 0.01 ¹⁾ | 10.0 | R V | < 0.02 --- | 0.200 0.400 |

d x p = spindle diameter x thread pitch

¹⁾ without considering reverse play

R = reduced play

V = preloaded

10.3 Tightening torques for screws

Screws of strength class 8.8 are used as standard. If other screws are used, they are specially marked. The tightening torques recommended by LINE TECH AG are defined in the following table.

| Tightening torques $M_{A \max.}$ [Nm] | | | | | | Friction factor for screws $\mu = 0.120$ | | | | |
|---------------------------------------|----------------|-------------|------|------|------|--|-------|-------|-------|--------|
| Screw acc. to | Material class | Thread size | | | | | | | | |
| | | M2 | M2.5 | M3 | M4 | M5 | M6 | M8 | M10 | M12 |
| ISO 4762 (DIN 912) | 8.8 | 0.36 | 0.73 | 1.27 | 3.00 | 5.90 | 10.10 | 24.60 | 48.00 | 84.00 |
| ISO 4762 (DIN 912) | 12.9 | 0.60 | 1.23 | 2.14 | 5.10 | 10.00 | 17.40 | 42.20 | 83.00 | 144.00 |
| ISO 47380 | 10.9 | 0.25 | 0.50 | 0.90 | 2.00 | 4.00 | 7.20 | 12.00 | 23.00 | 58.00 |

10.4 Permissible speeds

Permissible speed KE1 with KGT $\varnothing 12 \times \dots$ "

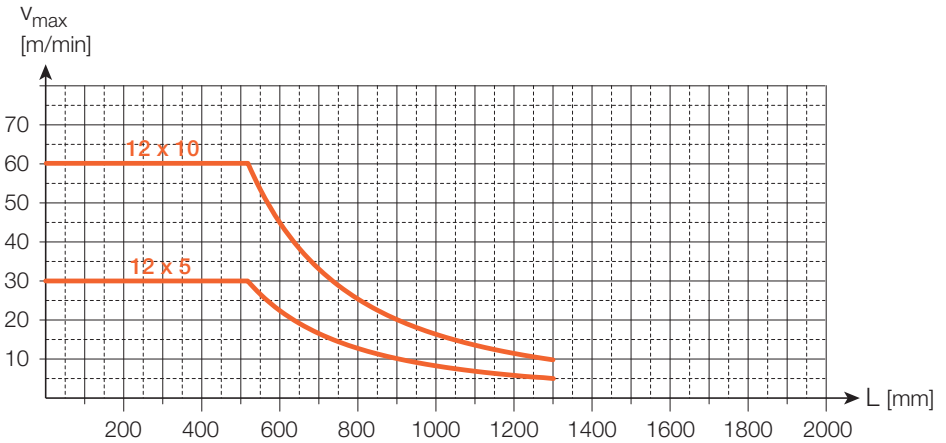

Permissible speed KE2 with KGT \varnothing 16 x..."

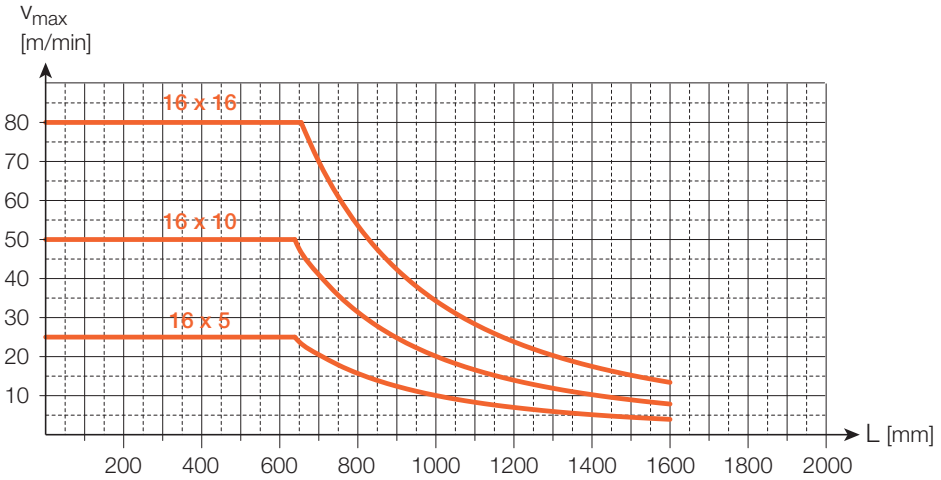

Permissible speed KE3 with KGT \varnothing 20 x..."

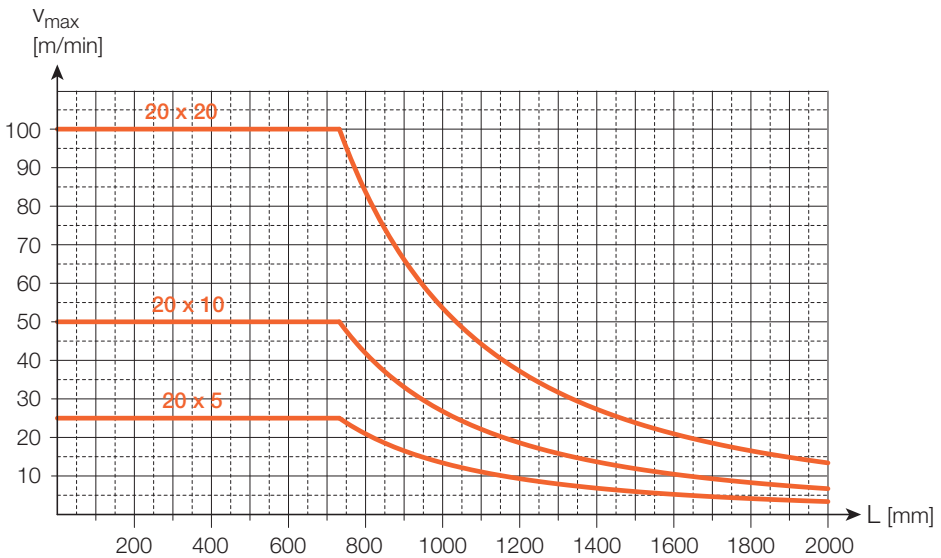

10.5 Compact unit: technical data

10.5.1 Exploded drawing and parts list KE1.2...AR...

1 carriage, ball screw drive, and cover strip

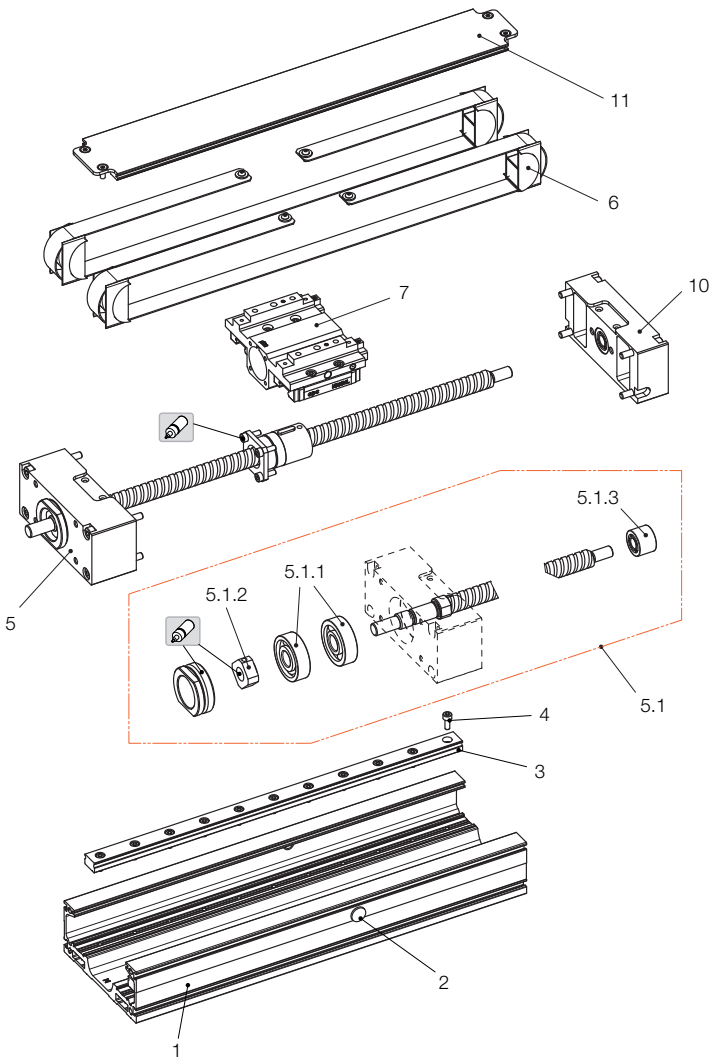

| | | | |
|-------|---------------------------------|----|------------------------------|
| 1 | Casing profile | 6 | Cover strips, complete |
| 2 | Sealing plug | 7 | Front carriage |
| 3 | Linear rail | 8 | - |
| 4 | Screw for linear rail | 9 | - |
| 5 | End plate with ball screw drive | 10 | End plate opposite the motor |
| 5.1 | Complete ball screw drive | 11 | Cover profile |
| 5.1.1 | Angular contact ball bearing | 12 | - |
| 5.1.2 | Lock nut | 13 | - |
| 5.1.3 | Needle bearing | 14 | - |

10.5.2 Exploded drawing and parts list KE2.2...AR...

1 carriage, ball screw drive, and cover strip

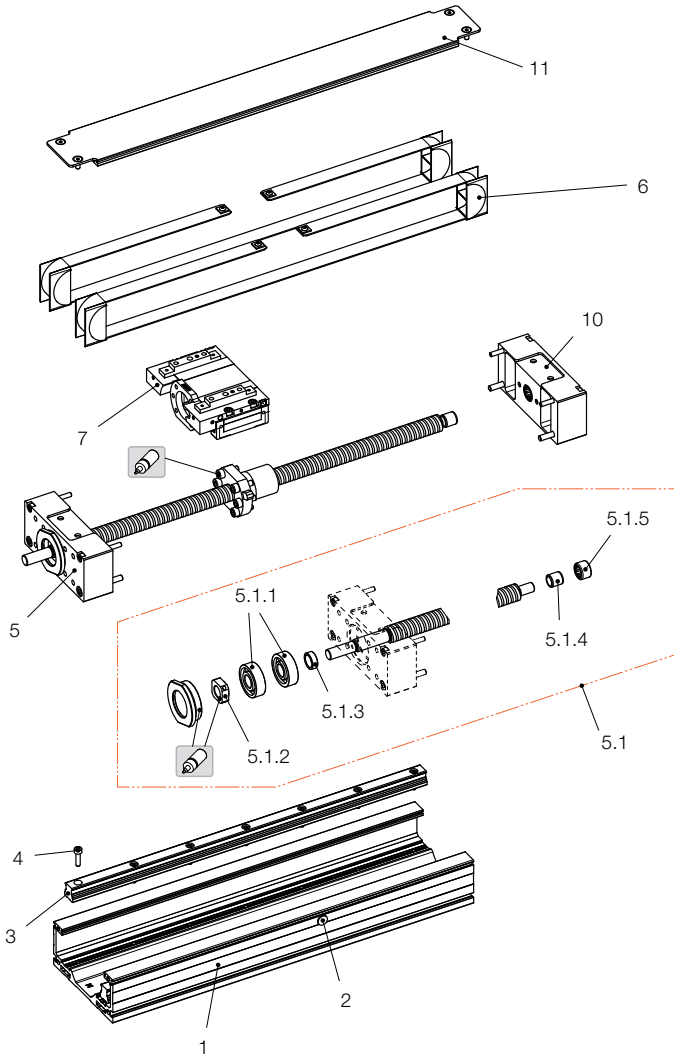

| | | | |
|-------|---------------------------------|-------|------------------------------|
| 1 | Casing profile | 5.1.4 | Inner ring |
| 2 | Sealing plug | 5.1.5 | Needle bearing |
| 3 | Linear rail | 6 | Cover strips, complete |
| 4 | Screw for linear rail | 7 | Carriage |
| 5 | End plate with ball screw drive | 8 | - |
| 5.1 | Complete ball screw drive | 9 | - |
| 5.1.1 | Angular contact ball bearing | 10 | End plate opposite the motor |
| 5.1.2 | Lock nut | 11 | Cover profile |
| 5.1.3 | Spacer ring | 12 | - |

10.5.3 Exploded drawing and parts list KE2.4...AR...

2 carriages, ball screw drive, and cover strip

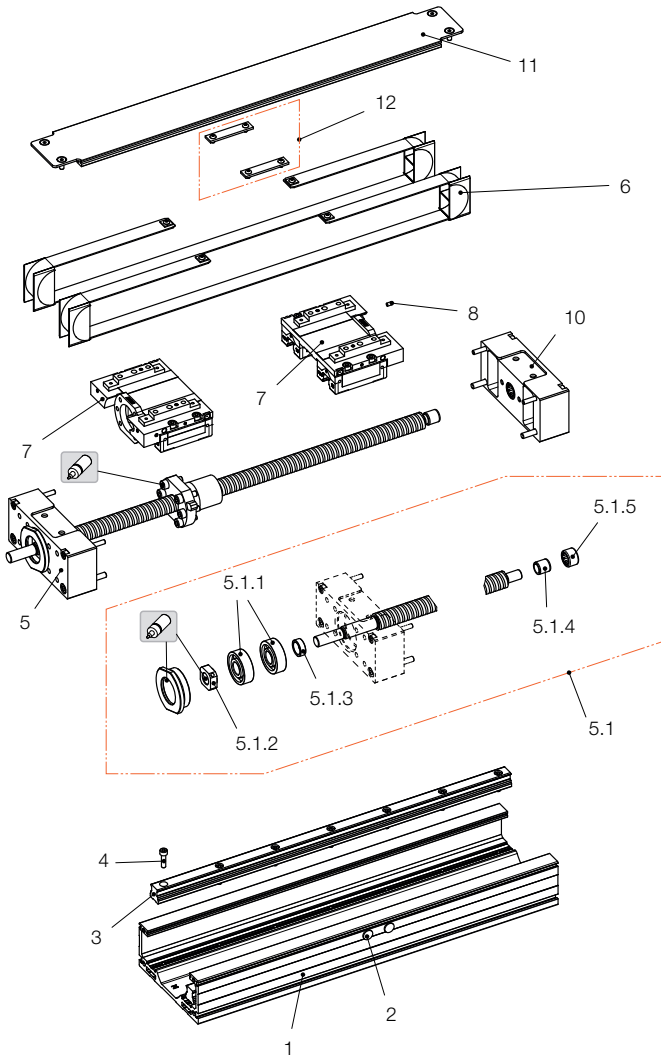

| | | | |
|-------|---------------------------------|-------|------------------------------|
| 1 | Casing profile | 5.1.4 | Inner ring |
| 2 | Sealing plug | 5.1.5 | Needle bearing |
| 3 | Linear rail | 6 | Cover strips, complete |
| 4 | Screw for linear rail | 7 | Carriage |
| 5 | End plate with ball screw drive | 8 | Sealing screw |
| 5.1 | Complete ball screw drive | 9 | - |
| 5.1.1 | Angular contact ball bearing | 10 | End plate opposite the motor |
| 5.1.2 | Lock nut | 11 | Cover profile |
| 5.1.3 | Spacer ring | 12 | Carriage connection |

10.5.4 Exploded drawing and parts list KE3.2...AR...

1 carriage, ball screw drive, and cover strip

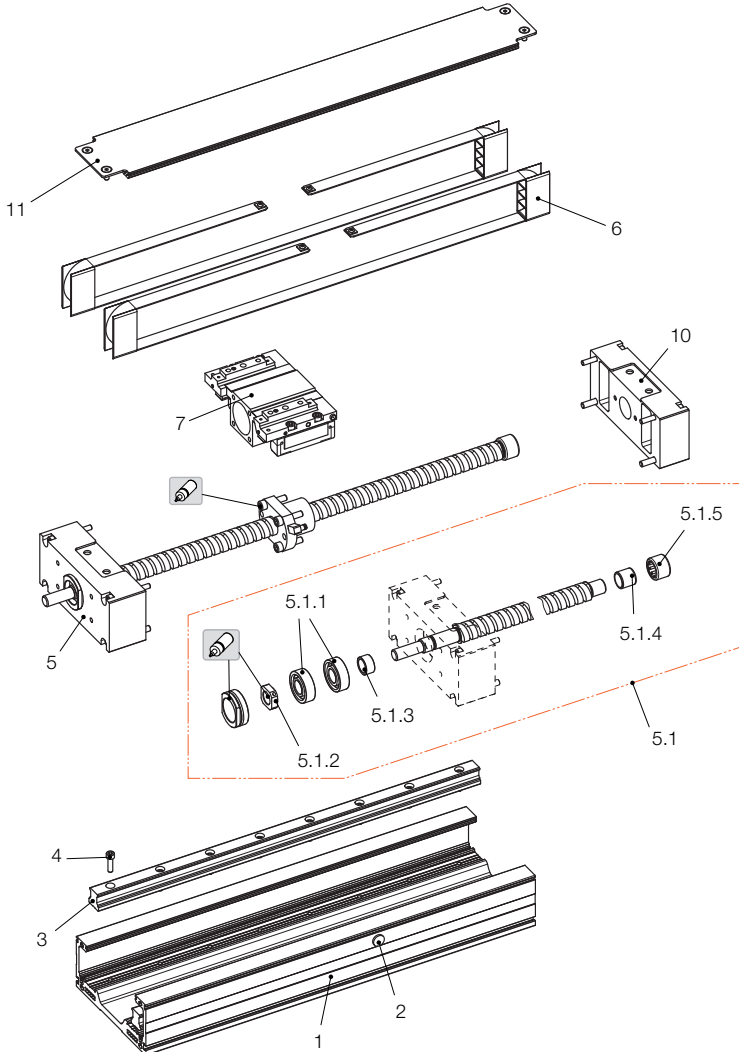

| | | | |
|-------|---------------------------------|-------|------------------------------|
| 1 | Casing profile | 5.1.4 | Inner ring |
| 2 | Sealing plug | 5.1.5 | Needle bearing |
| 3 | Linear rail | 6 | Cover strips, complete |
| 4 | Screw for linear rail | 7 | Carriage |
| 5 | End plate with ball screw drive | 8 | - |
| 5.1 | Complete ball screw drive | 9 | - |
| 5.1.1 | Angular contact ball bearing | 10 | End plate opposite the motor |
| 5.1.2 | Lock nut | 11 | Cover profile |
| 5.1.3 | Spacer ring | 12 | - |

10.5.5 Exploded drawing and parts list KE3.4...AR...

2 carriages, ball screw drive, and cover strip

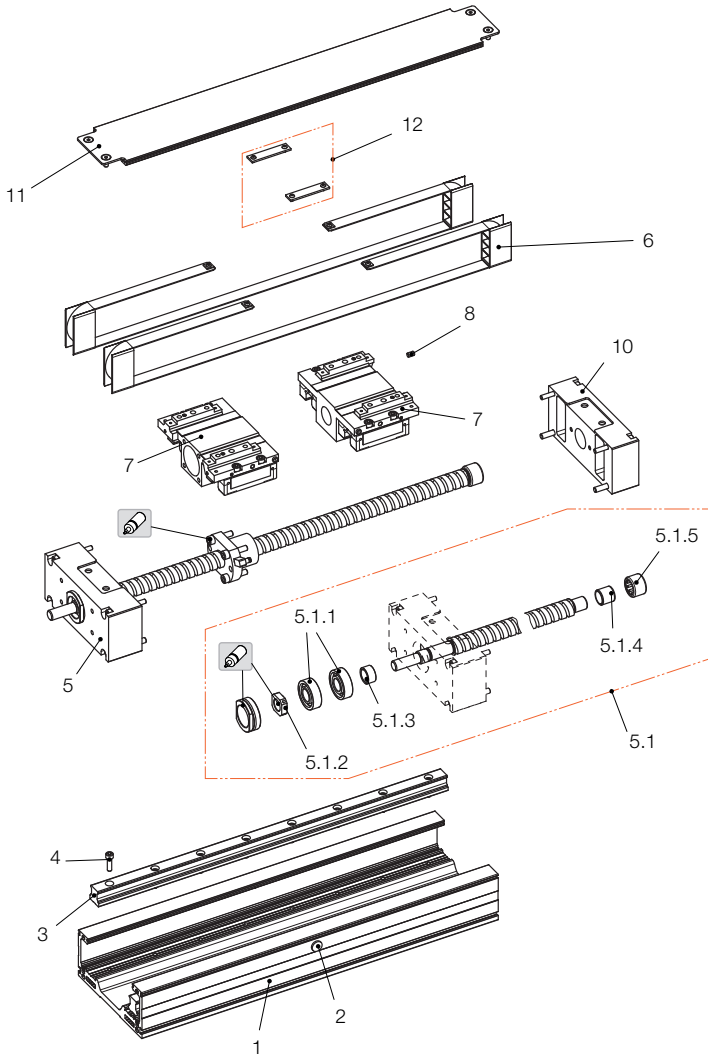

| | | | |
|-------|---------------------------------|-------|------------------------------|
| 1 | Casing profile | 5.1.4 | Inner ring |
| 2 | Sealing plug | 5.1.5 | Needle bearing |
| 3 | Linear rail | 6 | Cover strips, complete |
| 4 | Screw for linear rail | 7 | Carriage |
| 5 | End plate with ball screw drive | 8 | Sealing screw |
| 5.1 | Complete ball screw drive | 9 | - |
| 5.1.1 | Angular contact ball bearing | 10 | End plate opposite the motor |
| 5.1.2 | Lock nut | 11 | Cover profile |
| 5.1.3 | Spacer ring | 12 | Carriage connection |

10.5.6 Dimensions KE1.2...AR...

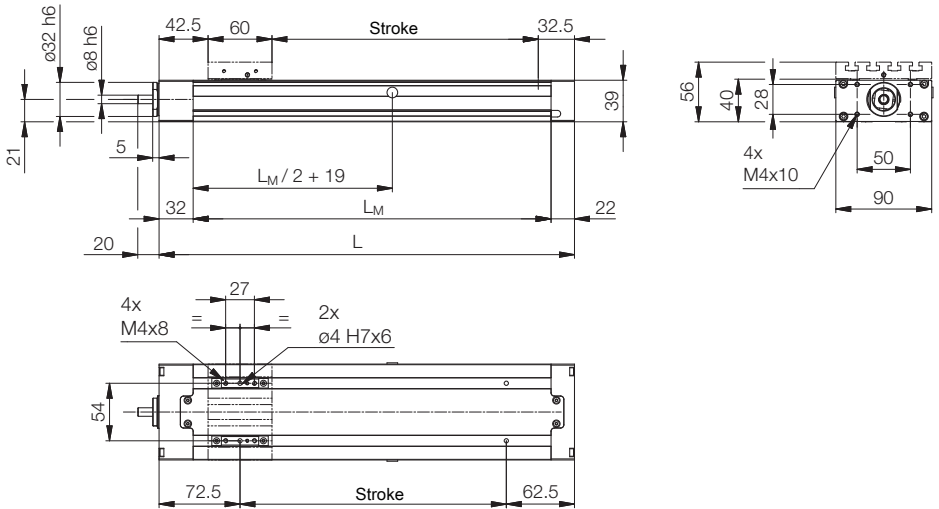

| Nominal size Designation | Dimensions | | Spindle length [mm] | Length of cover strip [mm] | Weight [kg] |
|-----------------------------|-----------------|------------------------|---------------------------|----------------------------------|-------------------------------------|
| | L [mm] | L _M [mm] | | | |
| KE1.2...AR... | Stroke + 135 | L - 12 | L + 10 | 2 x stroke + 220 | 1.77 kg + 0.410 kg/100 mm stroke |

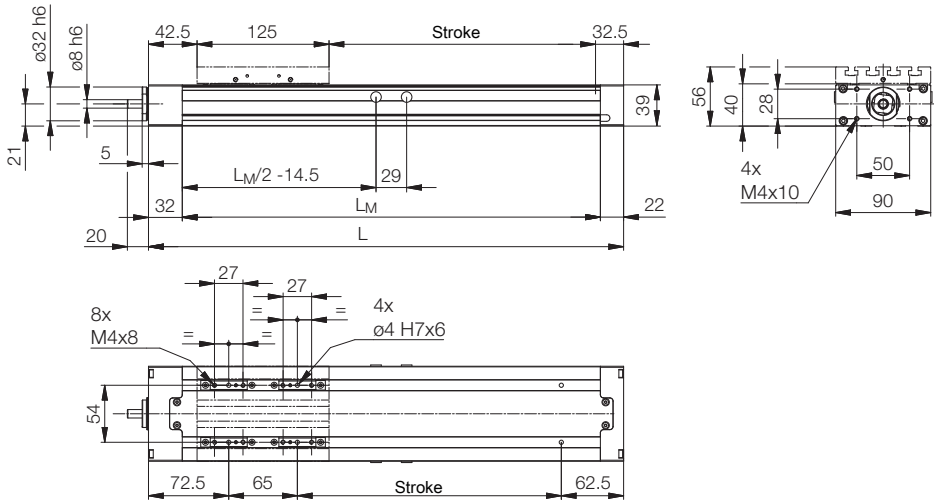
10.5.7 Dimensions KE1.4...AR...

| Nominal size Designation | Dimensions | | Spindle length [mm] | Length of cover strip [mm] | Weight [kg] |
|-----------------------------|-----------------|------------------------|---------------------------|----------------------------------|-------------------------------------|
| | L [mm] | L _M [mm] | | | |
| KE1.4...AR... | Stroke + 200 | L - 54 | L + 12 | 2 x stroke + 285 | 2.35 kg + 0.410 kg/100 mm stroke |

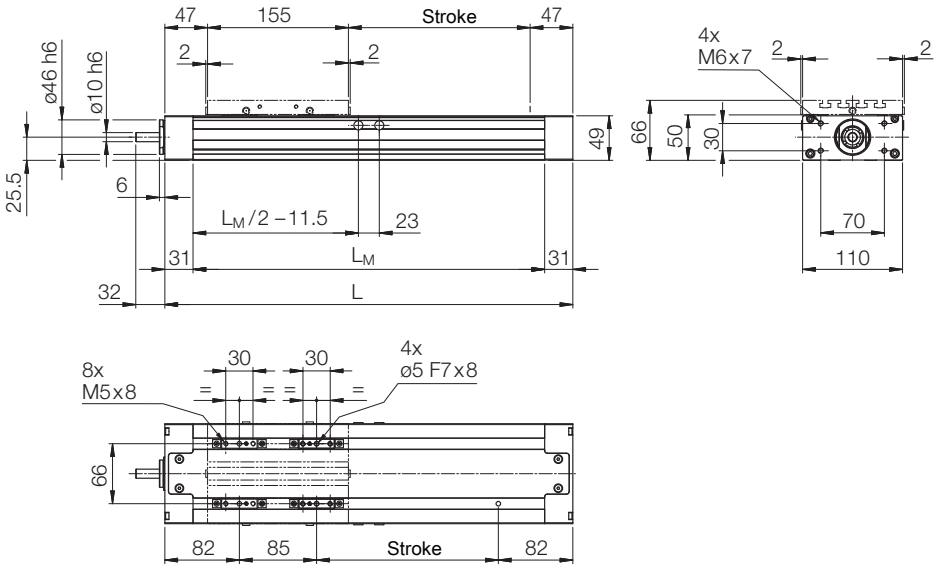
10.5.9 Dimensions KE2.4...AR...

| Nominal size Designation | Dimensions | | Spindle length [mm] | Length of cover strip [mm] | Weight [kg] |
|-----------------------------|-----------------|------------------------|---------------------------|----------------------------------|-------------------------------------|
| | L [mm] | L _M [mm] | | | |
| KE2.4...AR... | Stroke + 249 | L - 62 | L + 16 | 2 x stroke + 379 | 3.25 kg + 0.852 kg/100 mm stroke |

10.5.10 Dimensions KE3.2...AR...

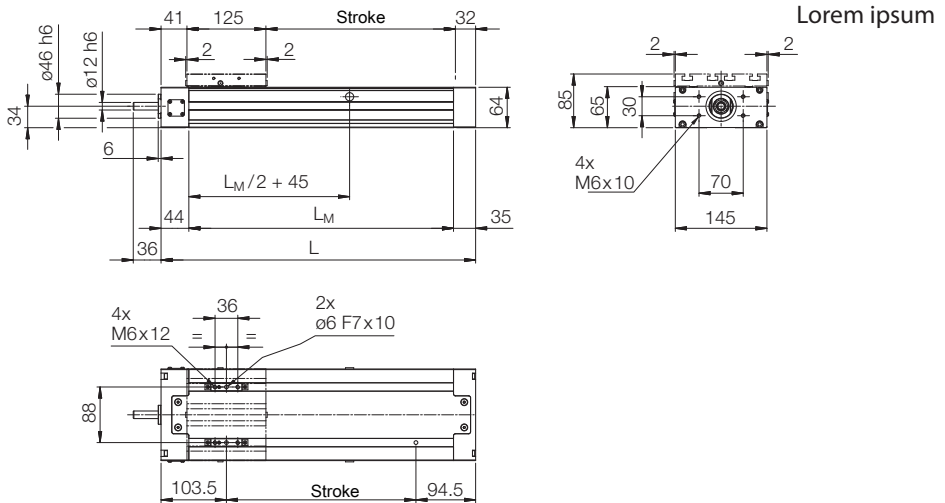

| Nominal size Designation | Dimensions | | | Length of cover strip [mm] | Weight [kg] |
|-----------------------------|-----------------|------------------------|---------------------------|----------------------------------|-------------------------------------|
| | L [mm] | L _M [mm] | Spindle length [mm] | | |
| KE3.2...AR... | Stroke + 198 | L - 79 | L + 17 | 2 x stroke + 354 | 5.40 kg + 1,232 kg/100 mm stroke |

10.5.11 Dimensions KE3.4...AR...

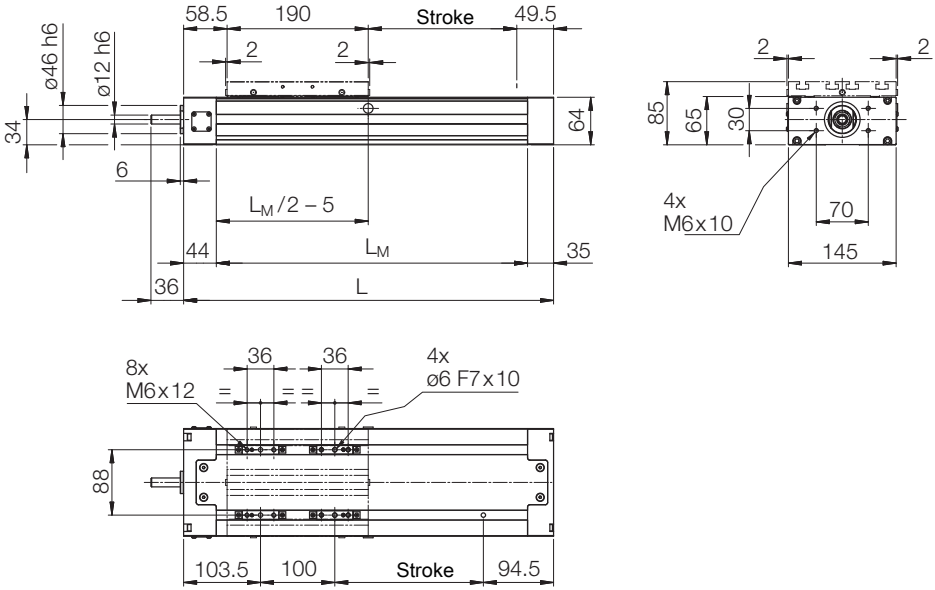

| Nominal size Designation | Dimensions | | | Length of cover strip [mm] | Weight [kg] |
|-----------------------------|-----------------|------------------------|---------------------------|----------------------------------|-------------------------------------|
| | L [mm] | L _M [mm] | Spindle length [mm] | | |
| KE3.4...AR... | Stroke + 298 | L - 79 | L + 17 | 2 x stroke + 454 | 7.62 kg + 1,232 kg/100 mm stroke |

11 Declaration of Incorporation

Declaration of Incorporation

according to EC Machinery Directive 2006/42/EC, Annex II 1. B
(Translation of original Declaration of Incorporation)

Manufacturer

Line Tech AG
Europastrasse 19
CH-8152 Glattbrugg

Module name

Compact unit with toothed belt drive

Type designation

according to type plate (see *Type plate* [▶ 22])

Serial number

according to type plate (see *Type plate* [▶ 22])

Manufacturing date

according to type plate (see *Type plate* [▶ 22])

We hereby declare that

the product specified below complies with the essential safety requirements of the Machinery Directive, including the amendments applicable at the time of the declaration, to the extent permitted by the scope of delivery, due to its design, construction and type in the version that we have launched on the market.

The following essential safety requirements of the Machinery Directive have been satisfied:

- 1.1.2 Principles for the integration of safety
- 1.1.3 Materials and products
- 1.1.5 Design of the machine for handling
- 1.3.2 Risk of breakage during operation
- 1.3.3 Risks due to falling or ejected objects
- 1.3.4 Risks due to surfaces, edges and corners
- 1.3.7 Risks due to moving parts
- 1.3.9 Risk of uncontrolled movements
- 1.5.2 Static electricity
- 1.5.4 Assembly errors
- 1.5.5 Extreme temperature
- 1.5.6 Fire
- 1.5.8 Noise
- 1.5.13 Emission of hazardous materials and substances
- 1.6.1 Maintenance of the partly completed machinery
- 1.7.2 Warning of residual risks

The product is a partly completed machine as defined by the Machinery Directive. The product is solely intended for installation in a complete system.

Relevant EU directives

EC Directive as amended 2006/42/EC - Machinery Directive

EMC Directive as amended by 2014/30/EU - Electromagnetic compatibility

Applied harmonized standards

The machine complies with the safety requirements of the following harmonized standards:

DIN EN ISO 12100:03/2011: Safety of machinery - General principles for design - Risk assessment and risk reduction

Technical documentation

The specific technical documentation in accordance with Annex VII, Part B has been compiled. The representative responsible for compiling the technical documentation undertakes to submit the documentation to the national authorities upon justified request. The documentation shall be submitted by post in paper form or on an electronic data carrier.

Documentation Officer

Line Tech AG, Europastrasse 19, CH-8152 Glattbrugg

Commissioning

The product may not be commissioned until it has been established that the machine in which the aforementioned product is installed complies with all the essential requirements of the Machinery Directive.



Daniel Rees
(Head of Technology/Design)

LINE TECH AG
Europastrasse 19
CH-8152 Glattbrugg

Glattbrugg, October 2025

Keyword index

A

| | |
|-----------|----|
| Accidents | 13 |
|-----------|----|

C

| | |
|---------------|----|
| Clamps | 33 |
| Connector box | 36 |
| Cross table | 50 |

D

| | |
|-----------------------|----|
| Danger areas | 16 |
| Danger level | |
| Danger to life | 7 |
| Personal injury | 8 |
| Property damage | 8 |
| Risk of injury | 8 |
| Decommissioning | 63 |
| Deflection | 30 |
| Disposal | 64 |
| Documents; applicable | 13 |

E

| | |
|--------------------------|--------|
| Environment | 19 |
| Environmental protection | 19, 64 |

F

| | |
|----------|----|
| Faults | 13 |
| Forklift | 24 |

G

| | |
|---------|----|
| Greases | 19 |
|---------|----|

H

| | |
|--------------------|--------|
| Hearing protection | 17, 19 |
|--------------------|--------|

I

| | |
|---|----|
| Installation position of limit switches | 38 |
| Instructions | 15 |
| Intended use | 14 |

L

| | |
|--------------------|--------|
| Liability | 11 |
| Limit switches | 36, 37 |
| Lubricants | 19, 57 |
| Lubrication | 58 |
| Lubrication points | 58 |

M

| | |
|----------------------|--------|
| Maintenance schedule | 55 |
| Manufacturer | 16 |
| Motor attachments | 41, 43 |

N

| | |
|-----------------------------------|----|
| Noise level | 19 |
| Note on working safely | 9 |
| Note regarding useful information | 9 |

O

| | |
|----------------------|----|
| Obligations | 10 |
| Oils | 19 |
| Operating site | 18 |
| Operation | 52 |
| Original spare parts | 12 |

P

| | |
|-------------------------------|--------|
| Personal protective equipment | 15, 16 |
| personnel | |
| instructed | 16 |
| unauthorized | 16 |
| Personnel requirements | 16 |
| Pin assignment | 39 |
| Product description | 21 |
| Protective clothing | 17 |
| Protective clothing; suitable | 17 |
| Protective gloves | 17 |
| Provisions | 5 |

Q

| | |
|---------------------|----|
| Qualification | 16 |
| qualified personnel | 16 |

R

| | |
|--------------------|----|
| Reading obligation | 5 |
| Reference switch | 37 |
| Repairs | 55 |

S

| | |
|------------------------------------|----|
| Safety | 15 |
| Safety goggles | 17 |
| Safety shoes | 17 |
| Service center | 16 |
| Sliding blocks | 35 |
| Sources of information; additional | 13 |
| Spare parts | 12 |
| Storage | 26 |
| Storage location | 5 |

T

| | |
|--|--------|
| Technical changes | 10 |
| Tightening torques of the clamping screw | 41, 43 |
| Transport item | 24 |
| Type plate | 22 |

W

| | |
|-------------------------|----|
| Warning symbols | 9 |
| Electric current | 9 |
| Environmental pollution | 9 |
| Suspended load | 9 |
| Warranty claims | 12 |
| Warranty conditions | 12 |

LINE TECH

Linear movements form the backbone of modern industrial production systems. LINE TECH AG has been providing linear technology solutions every day for over 25 years. LINE TECH AG is distinguished by a comprehensive range of components, linear and positioning systems coupled with the technical expertise of our employees.



Advanced services ranging from engineering to design, combined with flexible production, round off the product range and provide you, the customer, with a wide range of advantages.



Proprietary products

LINE TECH's proprietary products include modular, ready-to-install linear axes:

- Linear modules
- Bridge modules
- Compact units
- Positioning units



Systems / assemblies

Our engineering department develops customized solutions at the customer's request.



Components

Commercial products supplement the range, including linear guides, drives, and components:

- Linear guides
- Toothed belt drives
- Roller linear guides
- Ball bushings and shafts
- Ball rollers
- Comprehensive range of accessories
- Megatorque motors
- Linear motors

LINE TECH AG
Europastrasse 19
CH-8152 Glattbrugg
Switzerland

Telephone +41 (0) 43 211 68 68
Fax +41 (0) 43 211 68 69
info@linetech.ch

Revisionsstand:
1/22/2026

