

Translation of the original installation and maintenance instructions

DM.ZR-EN_25-05

DYNAMIC MODULES WITH A TOOTHED BELT DRIVE

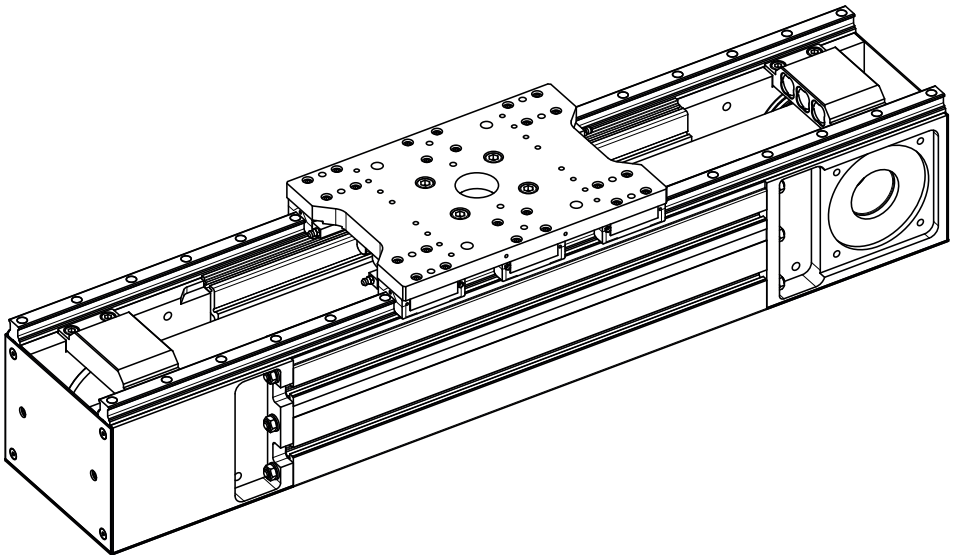

 Read the installation and maintenance instructions before carrying out any work!

Table of contents

1	General information.....	5
1.1	Information about these assembly instructions.....	5
1.2	Notes on use.....	6
1.3	Structure of the warnings.....	7
1.4	Symbols used.....	9
1.5	Disclaimer.....	10
1.6	Spare parts.....	12
1.7	Warranty conditions.....	12
1.8	Customer service and product monitoring.....	13
1.9	Other applicable documents.....	13
2	Safety.....	14
2.1	Introduction.....	14
2.2	Intended use.....	14
2.3	Foreseeable misuse.....	14
2.4	Responsibilities of the operating company.....	15
2.5	Personnel requirements.....	16
2.5.1	General personnel requirements.....	16
2.5.2	Qualifications.....	16
2.5.3	Unauthorized personnel.....	16
2.6	Personal protective equipment.....	16
2.7	Residual risks.....	18
2.7.1	Note.....	18
2.7.2	Mechanical hazards.....	18
2.7.3	Hazards at the operating site.....	18
2.7.4	Hazards due to noise.....	19
2.8	Environmental protection.....	19
3	Structure and function.....	20
3.1	Product overview.....	20
3.2	Product description.....	21
3.3	Type plate.....	22
4	Transport.....	23
4.1	Safety.....	23
4.2	Transportation with a forklift truck.....	24
4.3	Transport with the crane.....	24
4.4	Transport inspection and scope of delivery.....	25
4.5	Storage.....	26
5	Assembly.....	27
5.1	Safety.....	27
5.2	Assembly types.....	28

5.3	Condition on delivery	29
5.4	Gearbox selection	30
5.5	Fastening the dynamic module	31
5.5.1	General information	31
5.5.2	Fastening the dynamic module with clamps	31
5.5.3	Fastening the dynamic module with sliding blocks	33
5.6	Assembling limit switches	34
5.7	Assembling external sensors	36
5.8	Installing the motor and gearbox	36
5.8.1	General information	36
5.8.2	How the gearbox is mounted	37
6	Operation	38
6.1	Safety	38
6.2	Operating conditions	39
7	Maintenance	40
7.1	Safety	40
7.2	Repairs	41
7.3	Maintenance intervals	41
7.3.1	Notes	41
7.3.2	Maintenance plan	42
7.4	Maintenance work	42
7.4.1	Check the dynamic module for externally visible damage	42
7.4.2	Lubricating the dynamic module	43
7.4.3	Tensioning the toothed belt	47
7.5	Measures after completing the maintenance work	48
8	Faults	49
8.1	Safety	49
8.2	What to do in case of faults that pose a danger	49
8.3	Possible faults	50
8.4	Measures after completing the troubleshooting work	50
9	Disassembly and disposal	51
9.1	Safety	51
9.2	Decommissioning and disassembly	51
9.3	Disposal	52
10	Technical data	53
10.1	Exploded drawing and parts list	53
10.2	General technical data	55
10.3	Dimensions	56
10.4	Torques and load ratings	60
10.5	Permissible speeds	61

10.6 Tightening torques for screws..... 61

11 Declaration of Incorporation..... 62

Index 65

This document is protected by copyright and is intended for internal use only. Any provision of the document to third parties, any mode or form of reproduction – including excerpts –, any use and/or communication of the content, as well as translation into other languages, is not permitted without the prior consent of the manufacturer unless it is exclusively for internal use.

1 General information

1.1 Information about these assembly instructions

Using the assembly instructions

These assembly instructions allow you to work safely and efficiently with the dynamic module throughout all phases of the dynamic module's service life. All warnings and instructions in these assembly instructions must be observed in order to ensure safe working conditions.

Mandatory reading

The operating/maintenance personnel are required to carefully read and understand these assembly instructions before starting any work.

Storage location

The assembly instructions are an integral part of the linear module and must be kept readily available to the relevant personnel in the immediate vicinity of the dynamic module.

Resale

If the dynamic module is resold to a third party, these assembly instructions must also be included.

Other applicable documents, regulations and requirements

In addition to these assembly instructions, the instructions, notes and signs on the dynamic module in the annex also apply. Attach notes on technical changes to these assembly instructions. In addition, the local accident prevention regulations and general safety requirements for the area where the dynamic module is used apply.

Figures in these assembly instructions

Figures contained in these assembly instructions are provided for basic understanding and may vary from the actual version of the dynamic module.

Loss of the assembly instructions

If the assembly instructions are lost, request a replacement set immediately. Contact details Legal notice (See reverse side) .

1.2 Notes on use

Instructions and steps

The steps to be carried out by the operating personnel are displayed consecutively. The order of the steps must be observed.

Example:

a) Step 1

Lists

Lists without a mandatory sequence are displayed as a list preceded by a bullet point.

Example:

- Item 1
 - Item 1, subitem A
- Item 2

Lists with a mandatory sequence are displayed as a list preceded by a number.

Example:

1. First
2. Second

References to chapters/pages

References to specific chapters in which procedures and instructions are described are displayed as active links.

Example: see chapter *Information about these assembly instructions* [[▶ 5](#)].

Figures

All figures and drawings in these assembly instructions are intended for general illustration purposes. They may vary from the actual design of the dynamic module.

1.3 Structure of the warnings

The warnings used in these assembly instructions are introduced by signal words that indicate the extent of the danger.

The warning symbol also indicates the type of danger.

The following warnings are used in these assembly instructions:

Danger level, danger to life



⚠ DANGER

Danger to life!

Consequences in case of non-compliance...

▶ Notes on prevention

A warning assigned to this danger level indicates an imminently dangerous situation.

If the dangerous situation is not avoided, it will result in death or serious injury.

Follow the instructions in this warning to avoid the risk of death or serious injury to persons.

Danger level, risk of injury**⚠WARNING****Risk of injury!**

Consequences in case of non-compliance...

- ▶ Notes on prevention

A warning assigned to this danger level indicates a potentially dangerous situation.

If the dangerous situation is not avoided, it may result in death or serious injury.

Follow the instructions in this warning to avoid the potential risk of death or serious injury to persons.

Danger level, personal injury**⚠CAUTION****Personal injury due to...**

Consequences in case of non-compliance...

- ▶ Notes on prevention

A warning assigned to this danger level indicates a potentially dangerous situation.

If the dangerous situation is not avoided, it may result in minor or moderate injuries.

Follow the instructions in this warning to avoid the risk of injury to persons.

Danger level, property damage**NOTICE****Property damage due to...**

Consequences in case of non-compliance...

- ▶ Notes on prevention

A warning assigned to this danger level indicates possible damage to property.

If the situation is not avoided, property damage may occur.

Follow the instructions in this warning to avoid damage to property.

Note on working safely



SAFETY INSTRUCTIONS
<p>Working safely during...!</p> <p>Carry out all work in compliance with the following safety instructions:</p> <ul style="list-style-type: none"> ▶ Notes on working safely

This note contains important information and instructions for safe working during the following steps.

Follow the instructions in this note to avoid accidents and injuries.

Note on useful information



NOTE
<p>Note text...</p> <p>Consequences</p>



A note indicates additional information that is important for subsequent processing or simplifies the described work step.





1.4 Symbols used

Warnings in these assembly instructions are also marked with warning symbols.

Warning symbols

The following warning symbols are used in these assembly instructions:

Symbol	Meaning
	General warning
	Warning of electrical voltage

Symbol	Meaning
	Warning of hand injuries
	Warning of heavy loads
	Warning of suspended load
	Warning of environmental pollution

1.5 Disclaimer

Information in these assembly instructions

The information and warnings contained in these assembly instructions have been compiled taking into consideration the applicable standards, guidelines and regulations, the state of the art as well as our many years of experience. The scope of delivery or the design of the dynamic module may vary from the descriptions and figures provided here due to optional order items, the production of customized designs or the latest technical changes.

Obligations

In addition to the contractually agreed obligations, the manufacturer's General Terms and Conditions of Business and Delivery apply. They are subject to the laws in force at the time the contract is concluded.

Technical changes

The date of issue of these assembly instructions applies. We reserve the right to make technical changes to the dynamic module within the scope of further development in order to improve its performance features and safety.

Disclaimer in case of non-compliance

The manufacturer is not liable for damage and accidents resulting from the following:

- Non-intended use (*Intended use* [► 14]) of the dynamic module
- Non-compliance with the information and instructions in these assembly instructions
- Work performed on or with the dynamic module by unqualified or unauthorized personnel
- Installation of non-original spare parts
- Unauthorized conversions without written approval from the manufacturer

1.6 Spare parts

Spare parts can be acquired directly from the manufacturer. See the reverse side for contact details.



⚠ CAUTION

Incorrect or faulty spare parts.

Risk of injury, risk of damage, malfunctions or total failure!

- ▶ Only use original spare parts from the manufacturer or spare parts approved by the manufacturer.
- ▶ Always contact the manufacturer if there are any doubts.



NOTE

If non-approved spare parts are used, all warranty, service, compensation and/or liability claims against the manufacturer or its agents, dealers and representatives will be invalidated.

For all requests for spare parts or when ordering spare parts, always provide the complete data on the type plate (*Type plate* [▶ 22]).

1.7 Warranty conditions

Location

The warranty conditions are included in the purchase contract and the manufacturer's General Terms and Conditions.

Basic information

The manufacturer or sales partner will make the final decision on a warranty claim after all defective parts have been returned or possibly after an on-site inspection. The replacement of defective parts does not extend the warranty period for the module. In case of modifications or significant repairs carried out by the operator or third parties without the written consent of the manufacturer or sales partner, the warranty claim will be completely invalidated.

1.8 Customer service and product monitoring

Customer service

For problems and questions that cannot be solved using these assembly instructions and for technical information, please contact our customer service or sales partner; contact details (See reverse side) .

Product monitoring

We aim to continuously improve our products and are also interested in any experience gathered when using the linear module.

We are happy to receive information about problems with the linear module, faults during operation and errors that occur.

Always notify the manufacturer in the event of accidents or near-accidents.

1.9 Other applicable documents

In addition to the information contained in these assembly instructions, the information contained in the following sources of information, in particular the safety instructions, must also be taken into consideration:

- Information on the dynamic module's type plate
- Instructions for the modules used
- Work instructions issued by the operating company
- Safety data sheets for auxiliary and operating materials
- Local accident prevention regulations and regional regulations at the operating site of the dynamic module
- Data sheets for the installed components

2 Safety

2.1 Introduction

This section provides an overview of all the important safety aspects for ensuring optimum protection of personnel and for safe and smooth operation.

Failure to observe the instructions and warnings in these assembly instructions can result in serious hazards.

Only those risks that have been determined based on a risk assessment can be considered in these assembly instructions. Risks arising from the working conditions, the operating site and interfaces with external components must be determined and warnings must be added accordingly.

2.2 Intended use

The dynamic module is solely intended for use in industrial applications.

The dynamic modules are solely intended for installation in machines and are used to move, precisely position and transport light to medium loads.

The permissible values specified in the *Technical data* [▶ 53] chapter must be observed.

Any other use or use beyond this is considered improper use.

2.3 Foreseeable misuse

Any use for a purpose other than that specified in the *Intended use* [▶ 14] chapter is considered improper use.

Any use of the dynamic module that goes beyond and/or deviates from the intended use can result in dangerous situations.

The risk of improper use or misuse is borne solely by the operating company.

Misuse occurs, for example, if

- The dynamic module is operated outside the limits specified in *Technical data* [▶ 53].
- Modifications are made to the dynamic module.
- Safety devices are disabled.
- The dynamic module is used in an explosion-protected area.

2.4 Responsibilities of the operating company

Basic information

The owner of the dynamic module is generally subject to the legal requirements concerning occupational safety, since the dynamic module is intended for use in the commercial sector. In addition to the warnings in these assembly instructions, the safety, accident prevention and environmental protection regulations applicable to the area in which the dynamic module is used must therefore also be observed.

Risk assessment

The operating company must keep itself informed of the applicable health and safety regulations and carry out a risk assessment to determine any additional hazards arising from the specific working conditions at the place where the dynamic module is used.

Instructions

The operating company must issue, implement and document instructions in accordance with the results of the risk assessment at the workplace.

During the entire time the dynamic module is in use, the operating company is responsible for ensuring that the instructions it issues comply with the current legal requirements.

Responsibilities

The operating company must regulate the responsibilities for work on or with the dynamic module and designate a person responsible for the safe operation of the dynamic module and the coordination of all activities.

Information flow

The operating company must ensure that all personnel working on or with the dynamic module have read and understood these assembly instructions and other instructions. In addition, the operating company must train personnel at regular intervals and inform them of the dangers.

Personal protective equipment

The operating company must provide the personnel with the necessary personal protective equipment.

Safety requirements

If necessary, the operating company must ensure that the machine in which this dynamic module is to be installed or of which it is a component complies with the basic safety requirements and provisions of all relevant directives before commissioning.

Perfect working order

In order to keep the dynamic module in perfect working order at all times, the operating company must ensure that the maintenance intervals specified in these assembly instructions are observed.

2.5 Personnel requirements

2.5.1 General personnel requirements

Only persons who perform their work reliably and whose ability to react is not impaired, e.g., by drugs, alcohol or medication, are permitted to work on or with the dynamic module.

When selecting such personnel, the job-specific age requirements applicable at the location where the dynamic module is used must be observed.

2.5.2 Qualifications

Improper handling due to inadequate qualifications may result in serious injuries.

- All activities must only be carried out by qualified personnel
- Keep unqualified personnel away from the danger zones

The following qualifications are specified in the assembly instructions for various areas of activity:

Qualified specialist personnel

Qualified specialist personnel can carry out the assigned work and independently identify and avoid potential hazards due to their specialist training, knowledge and experience as well as knowledge of the relevant standards and regulations.

Manufacturer (service center)

Specific work must only be carried out by the manufacturer's specialist personnel. Other personnel are not authorized to carry out this work. Contact the manufacturer's service department to carry out the necessary work (see the Legal notice on the reverse side).

Instructed person (operator)

The instructed person has been informed by the operating company about the tasks assigned to them and about possible dangers in case of improper behavior.

2.5.3 Unauthorized personnel

Unauthorized personnel who do not meet the requirements described here are not aware of the dangers in the work area.

- Keep unauthorized personnel away from the work area.
- In case of doubt, address the unauthorized personnel and direct them out of the work area.
- Stop work as long as unauthorized personnel are present in the work area.

2.6 Personal protective equipment

Personal protective equipment must be worn during certain tasks to minimize health hazards. In addition to the personal protective equipment specified in these assembly instructions, the instructions posted in the work area must be observed. The following personal protective equipment must be worn depending on the work to be carried out:

Symbols	Meaning
---------	---------



Appropriate work clothing

is close-fitting work clothing with low tear resistance, tight sleeves and no projecting parts. It is primarily used to protect against being caught by moving machine parts. Do not wear rings, chains or other jewelry.



Safety shoes

are used to protect against heavy falling parts and slipping on slippery surfaces.



Safety gloves

are used to protect the hands from friction, abrasions, punctures or deeper injuries and from contact with hot surfaces.



Hearing protection

is used to protect hearing in the presence of harmful noise levels.



Protective goggles

are used to protect the eyes from flying small parts, dust or compressed air.



NOTE

External visitors or employees from other departments must also wear personal protective equipment when entering the work area.

2.7 Residual risks

2.7.1 Note

The following section lists residual risks that have been identified based on a risk assessment.



SAFETY INSTRUCTIONS

Note on working safely!

Failure to observe the safety instructions, warnings and instructions in these instructions may result in serious hazards.

- ▶ Always observe the safety instructions, warnings and handling instructions!
- ▶ Also observe the safety instructions provided in the other applicable documents!

2.7.2 Mechanical hazards

Moving dynamic module parts

Risk of injury between moving dynamic module parts!

Parts of the body can get trapped or crushed between moving dynamic module parts.

- Do not reach into moving dynamic module parts or handle moving dynamic module parts during operation.
- Do not open covers during operation.
- Observe the lag time: make sure that no parts are moving before opening the covers.
- Wear close-fitting clothing and tie back long hair.

2.7.3 Hazards at the operating site

Operating the dynamic modules at an unsuitable or insufficiently equipped operating site poses various hazards!

Safety deficiencies due to work that was carried out incorrectly due to inadequate lighting:

- Make sure there is sufficient lighting at the workplace.
- Have defective lights replaced immediately.

Sharp edges, corners and materials with sharp edges can cause abrasions and cuts to the skin:

- Be careful when working near sharp edges and corners and when handling materials with sharp edges.
- In case of doubt, wear protective gloves.

Dirt and objects lying around present sources of slipping and tripping:

- Always keep the work area clean.
- Remove objects that are no longer required.
- Mark tripping hazards with yellow and black marking tape.

- Immediately clean up any spilled liquids.

Risk of short circuits due to an unsuitable application area:

- Only operate the dynamic module indoors.
- Protect the dynamic module from moisture.

2.7.4 Hazards due to noise

The dynamic module itself does not emit any hazardous noise emissions. However, in combination with the connected machines, noise may be produced during operation, which may result in tinnitus or hearing loss.

- The emissions must be measured by the operating company after the entire system has been assembled:
 - If the measured noise level is ≥ 80 dB(A), the operating company must provide hearing protection.
 - If the measured noise level is ≥ 85 dB(A), the operating company must prescribe the use of hearing protection.

2.8 Environmental protection

Danger to the environment due to incorrect handling of environmentally hazardous substances, in particular incorrect disposal:

- Always observe the instructions provided below.
- If environmentally hazardous substances are accidentally released into the environment, take appropriate measures immediately. In case of doubt, notify the responsible local authority of the damage.
- Only collect, transport and store environmentally hazardous substances in suitable containers.

The following environmentally hazardous substances are used:

Lubricants

Lubricants, such as greases and oils contain toxic substances. They must not be released into the environment. They must be disposed of by a specialist disposal company in accordance with local regulations.

Machine parts

Replaced machine parts may be contaminated with grease and oil, for example, and therefore contain toxic substances. They must not be released into the environment. They must be disposed of by a specialist disposal company in accordance with local regulations.

3 Structure and function

3.1 Product overview

The following drawing shows a dynamic module in its maximum configuration. The actual scope of delivery may vary from this version.

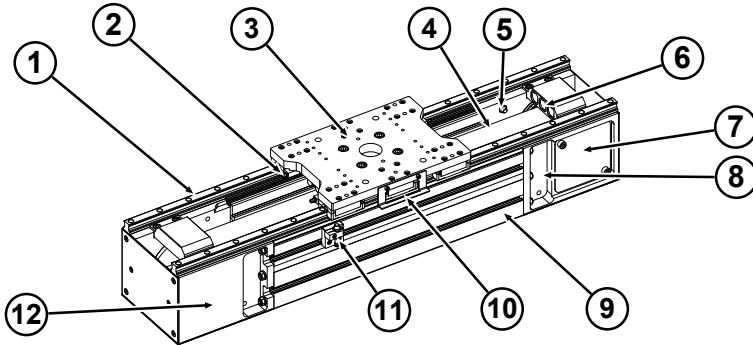

1	Guide rail	2	Central lubrication
3	Carriage	4	Toothed belt
5	Limit switch	6	Buffer
7	Cover plate	8	Drive housing
9	Base profile	10	Switching lug
11	Sensor holder	12	Deflection housing

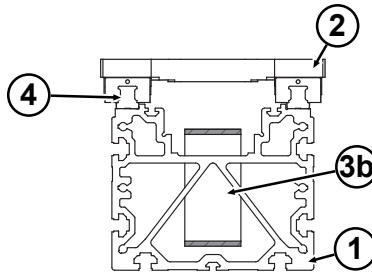

1	Base profile	2	Carriage
3b	Toothed belt	4	Linear rail guide

3.2 Product description

Dynamic modules with a toothed belt drive are modular, ready-to-install linear systems with a drive. Sealed guide elements are used in all sizes.

The base profile is made of an aluminum alloy and is manufactured via an extrusion process.

Optional integrated limit switches protect against overtravel. The respective mounting options are prepared as standard.

Additional external sensors can be used in combination with the motor and control unit to ensure the correct positioning of the carriage by means of a switching lug and sensor holder.

The selected design results in very high performance with highly compact dimensions.

The following load ratings are achieved:

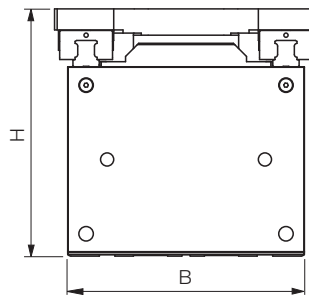

Dynamic module Type	Dimensions W x H [mm]	Load ratings	
		C ₀ [kN]	C ₅₀ [kN]
DM2.ZR	180 x 188	162.0	116.3
DM3.ZR	220 x 231	311.5	208.8

3.3 Type plate

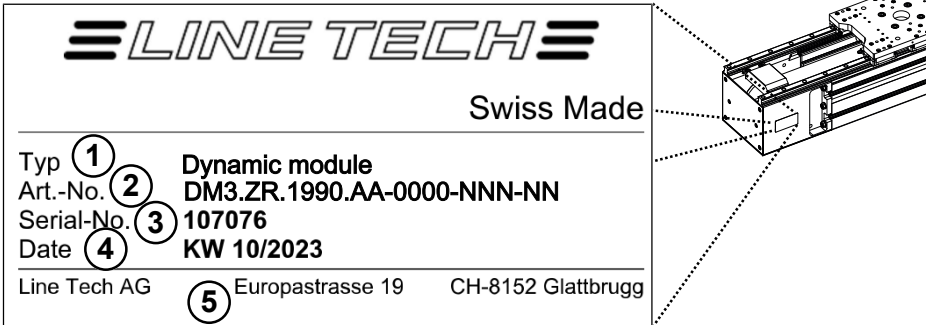

The following information is included on the type plate and makes it easy to identify the dynamic module:

- Type = type designation (1)
- Art. No. = part number (2)
- Serial No. = serial number (3)
- Date = manufacturing date; calendar week/year (4)
- Manufacturer address (5)



NOTE

If problems occur with the dynamic module, provide the manufacturer or sales partner with the information on the type plate.

4 Transport

4.1 Safety



SAFETY INSTRUCTIONS

Working safely while transporting the dynamic module!

Carry out all work in compliance with the following safety instructions:

- ▶ Comply with the provisions listed in the *Safety* [▶ 14] chapter for all work performed on/with the dynamic module.
- ▶ Observe the instructions and personnel requirements as per the *Personnel requirements* [▶ 16] chapter.
- ▶ Provide suitable forklift trucks or lifting gear for transportation.
- ▶ Wear personal protective equipment (safety shoes, protective gloves and hard hat).



NOTICE

Property damage due to improper transportation!

Improper transportation may result in property damage.

- ▶ Do not expose the parts to be transported to hard shocks during transportation.
- ▶ Make sure there is sufficient clearance during transportation.
- ▶ Always provide support for dynamic modules longer than 700 mm during transportation.
- ▶ Be careful when lifting and setting the unit(s) down.

4.2 Transportation with a forklift truck

Conditions for transportation

Packages that are secured on pallets can be transported using a forklift truck under the following conditions:

- The forklift truck must be designed for the weight of the items to be transported.
- The item to be transported must be securely fastened to the pallet.
- The forklift driver is authorized to do this.

Lifting packages

- a) Drive the forklift with the tines between or under the pallet's beams.
- b) Drive the tines in far enough that they protrude on the opposite side.
- c) Make sure that the pallet cannot tip if the center of gravity is eccentric. Observe the special information about the center of gravity on the packages.
- d) Lift the pallet with the transport unit and begin the transport.

4.3 Transport with the crane



WARNING

Danger to life from suspended loads!

Danger from falling or uncontrolled swinging parts.

- ▶ Never stand under suspended loads.
- ▶ Do not attach lifting gear to protruding module parts or to eyelets on attached components. Ensure that the slings are securely fastened.
- ▶ Only use approved lifting gear and slings with sufficient load capacity.
- ▶ Transport may only be carried out by personnel trained for this purpose.

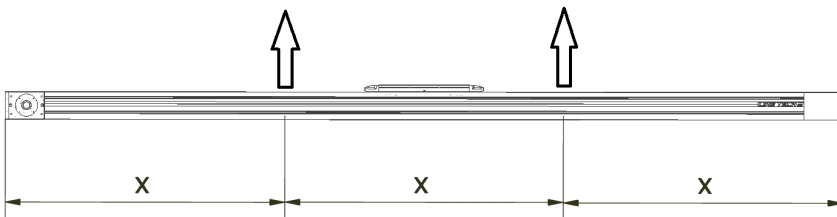

Conditions for transportation

The bridge modules or packages that are secured to pallets or packed in crates can be lifted and moved with a crane (for bridge modules or packages that exceed a length of 9 meters, consult the manufacturer).

Ensure that

- the slings are designed for the weight to be lifted.
- the crane operator is authorized to do so.

Lifting bridge modules or packages

Lift bridge module or packages as follows:

- a) Ensure that the carriage is positioned approximately in the center.
- b) Attach bridge modules or packages.
- c) Attach two lifting straps at equal distances ($\frac{1}{3}$ / $\frac{1}{3}$ / $\frac{1}{3}$) and lift vertically.
- d) Do not choose an angle of attack that is too flat.
- e) Ensure that ropes and straps, etc. are not twisted and that the bridge module or packages are securely fastened.
- f) Lift the bridge module or packages and begin the transport operation.

4.4 Transport inspection and scope of delivery

Transport inspection

Check that the delivery is complete and that there is no transport damage immediately upon receipt.

If there is any visible external transport damage, proceed as follows:

- Do not accept the delivery or only accept it with reservations.
- Record the extent of the damage on the transport documents or on the carrier's delivery document.
- Submit a complaint.



NOTE

Report any defect as soon as it is detected. Claims for damages can only be made within the valid complaint periods.

Scope of delivery

Refer to the delivery document for the scope of delivery. The scope of delivery of the product includes:

- Dynamic module according to the order confirmation
- Assembly instructions
- Additional and special accessories according to the order

4.5 Storage



NOTICE

Property damage due to improper storage!

Improper storage may result in property damage.

- ▶ Only store the dynamic module/dynamic module parts in compliance with the following conditions.
- ▶ Be careful when lifting and setting the unit(s) down.

If the dynamic modules are not used for more than two months or are stored before installation, observe the following conditions:

- Make sure that the dynamic modules are clean. Clean the dynamic modules if necessary.
- Do not store outdoors.
- Store in a dry and dust-free place.
- Do not expose to aggressive media.
- Protect it from sunlight.
- Avoid mechanical shocks.
- Store dynamic modules in a box that is well padded.

5 Assembly

5.1 Safety



SAFETY INSTRUCTIONS

Working safely while assembling the dynamic module!

Carry out all work in compliance with the following safety instructions:

- ▶ Comply with the provisions listed in the *Safety* [▶ 14]chapter for all work performed on/with the dynamic module.
- ▶ All installation work must only be carried out by specially trained personnel (see the *Personnel requirements* [▶ 16] chapter).
- ▶ Work on electrical systems must only be carried out by qualified personnel (see the *Qualifications* [▶ 16] chapter).
- ▶ Wear protective equipment in accordance with local accident prevention regulations for all assembly work.
- ▶ Make sure that there is sufficient space for assembly before starting work.
- ▶ Make sure that the assembly area is tidy and clean! Loose components and tools lying on top of each other or lying around may cause accidents.
- ▶ If components have been removed or adjusted, ensure correct assembly, reinstall all fastening elements and observe the screw tightening torques.
- ▶ Do not stand under suspended loads.
- ▶ Observe environmental protection instructions. If environmentally hazardous substances are accidentally released into the environment, take appropriate measures immediately. In case of doubt, notify the responsible local authority of the damage.

5.2 Assembly types

When designing linear units, the assembly method is usually not taken into consideration (undefined contact points » order code A). In this case, the linear module assumes the accuracy of the mounting surface (assumption: the mounting surface is stiffer than the base profile).

The subsequent installation situation can already be taken into consideration during the machining of the base profile and defined customer-specific contact points are incorporated into the JIT production (defined contact points » order code B).

If the linear movement must be as accurate as possible, defined contact points are also machined. They then function as the basis for machining the guide rail supports during clamping (machined contact points » order code C).

[A] Undefined contact points (standard)

Undefined contact points on the base profile (unmachined).
» Straightness 0.8 mm/1000 mm

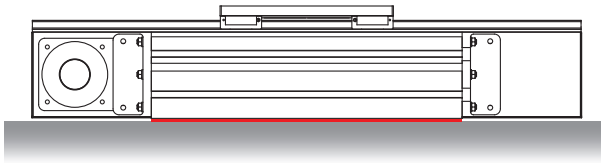

[B] Defined contact points

Defined contact points on the base profile (unmachined).
» Straightness 0.4 mm/1000 mm

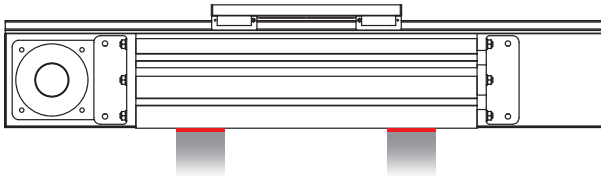

[C] Machined contact points

Over-milled defined contact points on the base profile.
» Straightness 0.2 mm/1000 mm

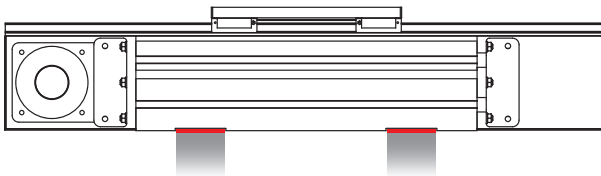

Installation position

The linear units are installed horizontally (as shown) or overhead as standard. If your application requires a vertical or lateral installation position, please contact our Technical Sales department in advance.

5.3 Condition on delivery

LINE TECH dynamic modules are available in various delivery conditions.

The following delivery conditions are possible:

[N] Without gearbox (standard version)

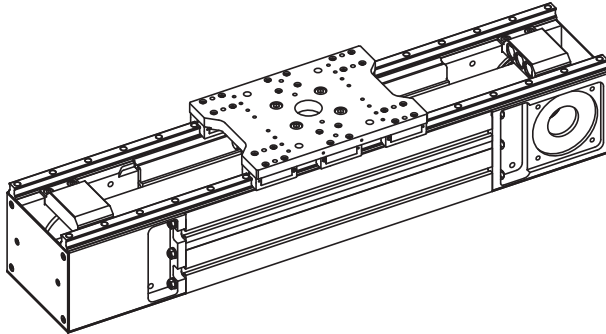

[A] Gearbox on left is fully assembled

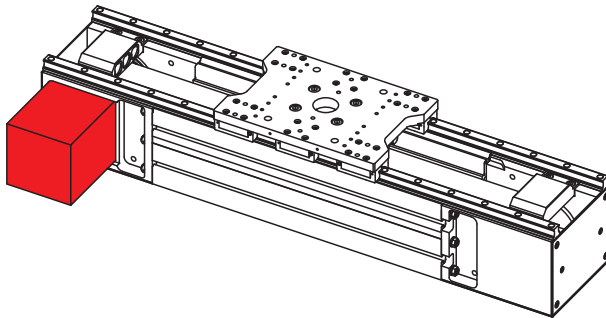

[B] Gearbox on right is fully assembled

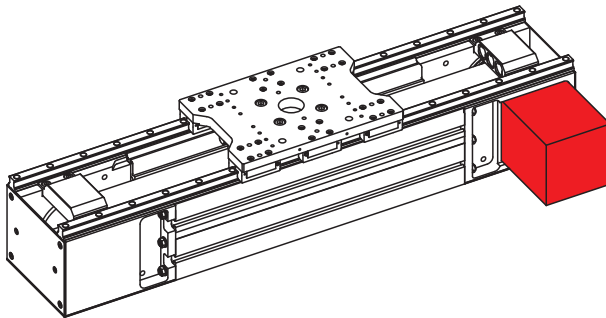

5.4 Gearbox selection

The dynamic modules with a toothed belt drive can each be equipped with planetary gearbox (1) or angular gearbox (2):

DM2.ZR... Standard gearbox

①

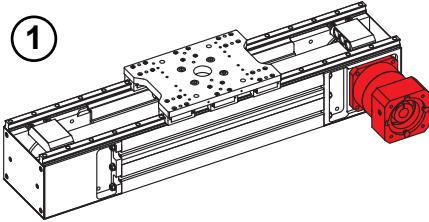

②

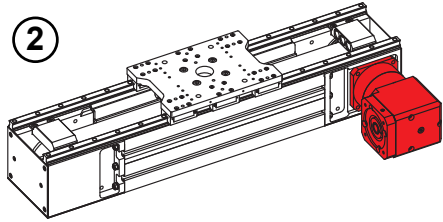

DM3.ZR... Standard gearbox

①

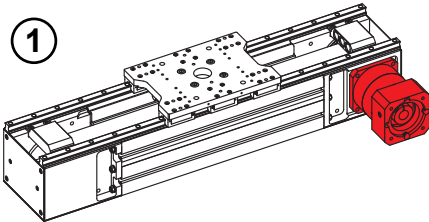

②

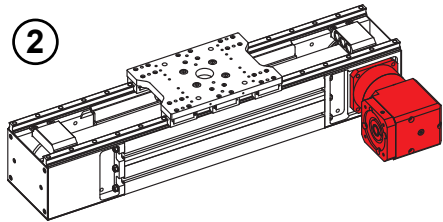

5.5 Fastening the dynamic module

5.5.1 General information

The dynamic modules can be attached using clamps or T-slot nuts.



NOTICE

Property damage due to improper fastening!

If end plates are used as load-bearing elements, the dynamic module may be damaged.

- ▶ Only fasten or support dynamic modules on the base profile and not on the end plates.

5.5.2 Fastening the dynamic module with clamps

Overview

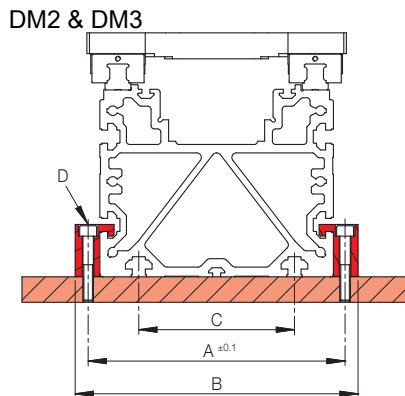

Nominal size	Dimensions [mm]			
	A	B	C	D <small>(DIN912)</small>
DM2...	198	218	120	M8x50 ¹⁾
DM3...	238	258	150	M8x60 ¹⁾

¹⁾Recommended screw length

Clamps

Recommended number of clamps:
3 pieces per meter and side

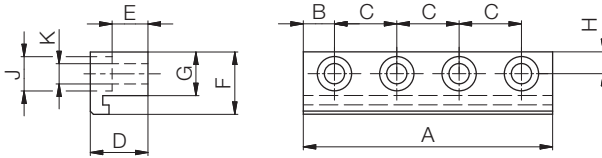

The clamps can be ordered from LINE TECH AG according to the following table.

Nomin- al size	Dimensions [mm]										Weight [kg]	Art. No.
	A	B	C	D	E	F	G	H	J	K		
DM2...	110	10	30	40	31	30	19	10	Ø 15	Ø 9	0.610	P-55247
DM3...	110	10	30	50	41	30	19	10	Ø 15	Ø 9	0.754	P-54856

Assembly

- Fasten the dynamic modules using clamps.
- Secure screws with Loctite.
- Observe the tightening torques (see the *Tightening torques for screws* [61] chapter).

5.5.3 Fastening the dynamic module with sliding blocks

Usage

Sliding blocks with the corresponding groove width can be used to fasten attachments and extensions to the base profile.

Sliding block types

The type of sliding block to be used depends on the groove width:

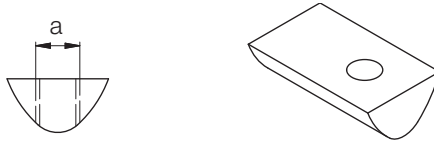

Dimensions [mm]		Material
Groove width	a (thread)	
Groove 6	M4/M5/M6	Steel
Groove 10	M4/M5/M6/M8	Steel
Groove 14	M12	Steel

Assembly

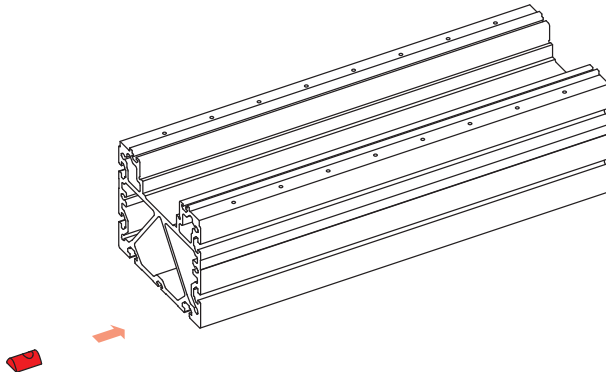

a) Push the sliding blocks into the corresponding groove.

5.6 Assembling limit switches

Limit switch

Limit switches are required in combination with a control unit to limit the stroke and to determine a reference point for setting the zero point. The limit switches are triggered shortly after the end of the effective stroke (the stroke from limit switch to limit switch is greater than the effective stroke).

For assembly, either threaded holes M8x1 (DM3.ZR...) or through-holes \varnothing 8.2 mm (DM2.ZR...) are prepared on both sides of the end plates. The limit switches are triggered by the carrier on the slide.

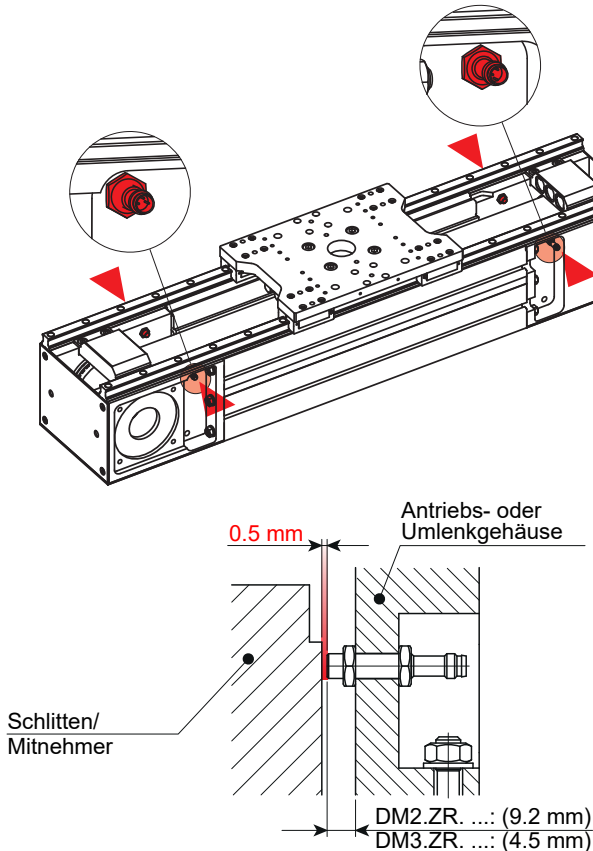

LINE TECH offers inductive limit switches with M8 connectors as standard:

- PNP normally closed contact (PNP NC)
Art. No. I08H004

Limit switch cable

LINE TECH recommends cables with M8 cable sockets and loose stranded wires for the cabling.

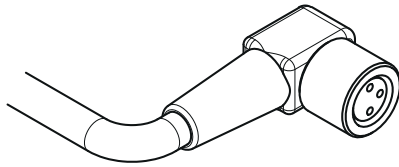

Cable	Art. No.
With 2-m cable	S56-02M (standard)
With 5-m cable	S56-05M
With 10-m cable	S56-10M

5.7 Assembling external sensors

Sensor holder

LINE TECH recommends using sensor holders to assemble additional external sensors with $\varnothing 8$ mm.

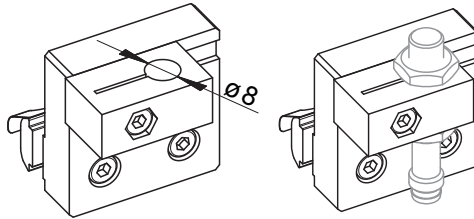

This sensor holder can be used to detect the position of the carriage in relation to the effective stroke as indicated below:

- DM2.ZR » up to 30 mm before end of stroke
- DM3.ZR » full effective stroke

5.8 Installing the motor and gearbox

5.8.1 General information



⚠ DANGER

Danger of electric shock!

There is a risk of electric shock if contact is made with live components.

- ▶ Work on the electrical equipment must only be carried out by qualified electricians.
- ▶ De-energize the dynamic module before carrying out any work (disconnect the power plug).



NOTE

Observe the information in the manufacturer's instructions regarding the motors and gearboxes to be installed.

5.8.2 How the gearbox is mounted

Assemble the gearbox (straight planetary gearbox or angular gearbox) on the dynamic module as follows:

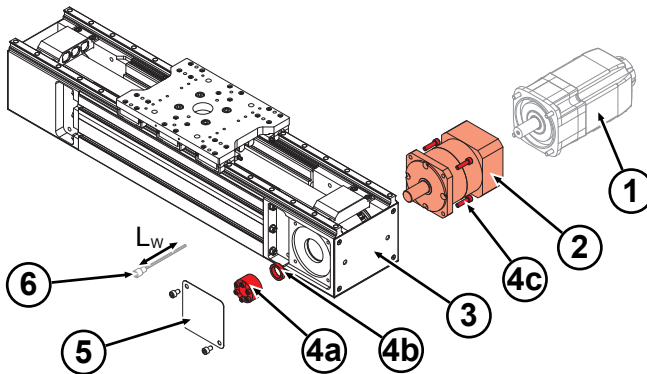

- | | | | |
|----|-----------------------------------|----|---|
| 1 | Motor (customer-side) | 2 | Gearbox |
| 3 | Dynamic module | 4a | Gearbox mounting kit: clamping set |
| 4b | Gearbox mounting kit: spacer ring | 4c | Gearbox mounting kit: 4 screws |
| 5 | Cover plate (including 2 screws) | 6 | Allen key
(provided by customer, for the minimum tool length, see table below) |

- Mount the gearbox (2) with screws (4c) (without any play but can be turned, i.e., only hand-tight) on the dynamic module (3).
- Push the spacer ring (4b) from the opposite side onto the stop.
- Push the clamping set (4a) from the opposite side onto the stop and tighten it using the Allen key provided by the customer according to the table.
- Tighten the screws (4c) to the nominal torque.
- Optional: mount the cover plate (5).

Nominal size	Clamping set			Allen key (provided by the customer)	
	Screws	Torque [Nm]	Condition	WAF [mm]	Tool length L_w [mm]
DM2.ZR...	6 x M6	14	Oiled, without additives	5	≥ 120
DM3.ZR...	6 x M6	16.5	Oiled, without additives	5	≥ 140

6 Operation

6.1 Safety



SAFETY INSTRUCTIONS



Working safely while operating the dynamic module!

Carry out all work in compliance with the following safety instructions:

- ▶ Comply with the provisions listed in the *Safety* [▶ 14]chapter for all work performed on/with the dynamic module.
- ▶ Wear protective equipment in accordance with the accident prevention regulations at the operating site.
- ▶ Carry out all operating steps in accordance with the information in these assembly instructions.
- ▶ Before starting work, make sure that all covers and safety devices are installed and functioning properly.
- ▶ Never disable safety equipment during operation.
- ▶ Make sure the work area is tidy and clean! Loose components and tools lying on top of each other or lying around may cause accidents.

6.2 Operating conditions

Normal operating conditions

Normal operating conditions		
Ambient temperature	5°...40°C (non-condensing)	
		 °C
Permissible operating temperature of components	Max. 80°C	(Excluding gearboxes/motors)
Processing speed	See <i>Permissible speeds</i> [▶ 61]	
Load	See <i>Technical data</i> [▶ 53] ff.	
Minimum stroke	Type	Minimum stroke
	DM2.ZR...	≥ 70mm
	DM3.ZR...	≥ 85mm

Special operating conditions

For applications in special operating conditions, such as moisture, dirt, dust (fiberglass and wood), aggressive atmospheres, extreme climatic conditions and/or strong temperature fluctuations, short strokes and others, contact LINE TECH AG before commissioning.

The specified maximum values refer to one domain. If several requirements are combined (temperature/speed/load), this must be taken into consideration in the design.

7 Maintenance

7.1 Safety



SAFETY INSTRUCTIONS

Working safely while maintaining the dynamic module!

Carry out all work in compliance with the following safety instructions:

- ▶ Comply with the provisions listed in the *Safety* [▶ 14] chapter for all work performed on/with the dynamic module.
- ▶ All maintenance work must only be carried out by specially trained personnel (see the *Personnel requirements* [▶ 16] chapter).
- ▶ Work on electrical systems must only be carried out by qualified electricians (see the *Qualifications* [▶ 16] chapter).
- ▶ Wear protective equipment in accordance with local accident prevention regulations for all maintenance work.
- ▶ Before starting work, switch off the electrical supply and secure it against being switched on again.
- ▶ Make sure that there is sufficient space for assembly before starting work.
- ▶ Make sure that the assembly area is tidy and clean! Loose components and tools lying on top of each other or lying around may cause accidents.
- ▶ If components have been removed or adjusted, ensure correct assembly, reinstall all fastening elements and observe the screw tightening torques.
- ▶ Observe the specified maintenance intervals.
- ▶ Observe environmental protection instructions.

7.2 Repairs



NOTE

Repairs to the dynamic module are not considered maintenance work. They must only be carried out by trained specialist personnel or the manufacturer's service personnel.

7.3 Maintenance intervals

7.3.1 Notes

The maintenance work

- The maintenance work specified on the following pages and
- the maintenance work on purchased components in accordance with the associated documentation

is required to ensure safe and smooth operation of the dynamic module.

The specified maintenance intervals are based on our many years of experience and knowledge. If excessive wear of wearing parts is detected or if faults occur more frequently, the operating company must shorten the time between two maintenance intervals accordingly.

Keep a maintenance log as verification that the required maintenance work has been carried out.



NOTE

Verification that the required maintenance work has been carried out is a mandatory requirement for claiming any warranty services.

Contact the manufacturer if there are any doubts.

7.3.2 Maintenance plan

Interval	Maintenance work	Description	Personnel
Daily	Check the dynamic module for externally visible damage.	<i>Check the dynamic module for externally visible damage</i> [▶ 42]	Specialist personnel
Every 3 months	Lubricate the dynamic modules	<i>Lubricating the dynamic module</i> [▶ 43]	Specialist personnel
As needed	Tension the belt	Setting the toothed rack play	Specialist personnel

7.4 Maintenance work

7.4.1 Check the dynamic module for externally visible damage

Daily or before each use

- a) Check the dynamic module for externally visible damage and defects.
- b) Visually check that externally attached fasteners, electrical cables and plug connections are in perfect working order.

If changes occur that put the safety of personnel and systems at risk, immediately shut down the dynamic module.

7.4.2 Lubricating the dynamic module

7.4.2.1 General information on lubrication

Lubrication

using a grease gun via grease nipple as standard:

Lubrication cycle (or)

- Every 500 operating hours
- Every 100,000 cycles
- Every ...km according to F/C diagram
- Every 3 months
- After a standstill longer than 7 days

Procedure:

- a) Clean the guides with an oiled cleaning cloth to remove deposits and old grease.
- b) Position the carriage in the center of the stroke.
- c) One stroke with grease gun "01.103" per carriage.
- d) Move the unit to both end positions at 50 mm/s.
- e) Another stroke with grease gun "01.103" per carriage.
- f) Move the unit to both end positions at 50 mm/s.
- g) Remove excess grease with an oiled cleaning cloth.

Lubricants



NOTE

The axles may only be lubricated with grease. LINE TECH AG recommends specific greases as shown in the table below. When using other greases (third-party products), their compatibility with the standard grease must first be checked. Observe the safety data sheet.

The initial lubrication is carried out by LINE TECH AG using Microlube GBU-Y 131. The bearings used are generally maintenance-free and do not need to be relubricated under normal conditions.

Lubricant table

Components	With grease gun	With central lubrication
Linear guides	Microlube GBU-Y 131 Alternative: Klüberplex BEM 34-132	Klübersynth G 34-130

F/C ratio

The F/C ratio is determined by load F calculated by the customer and divided by the corresponding load rating C_{50} .

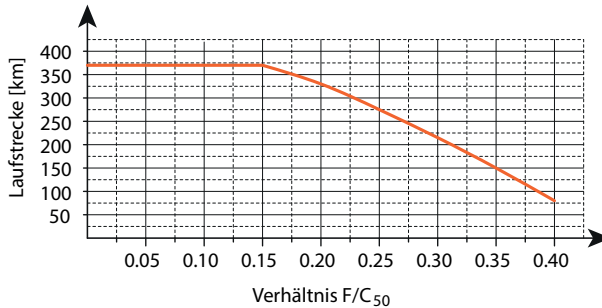

For the load ratings, see the *Torques and load ratings* [▶ 60] chapter.



NOTE

Correct and sufficient lubrication can considerably extend the service life of the dynamic modules.

You can achieve optimal results with minimum grease consumption by moving the guide elements (carriages) slowly while relubricating the system.

All bearings used are lubricated for life and do not require any maintenance.



NOTE

After a standstill of longer than 1 year, relubricate the system until the fresh grease emerges at the lubrication points. The lubricant age should never exceed 2 years in the entire system.

7.4.2.2 Lubrication points

Lubrication of the carriages (DM2/DM3.ZR...)

- The lubrication points are located on the carriage.
- Recommended standard grease: Microlube GBU Y 131

Standard: individual lubrication

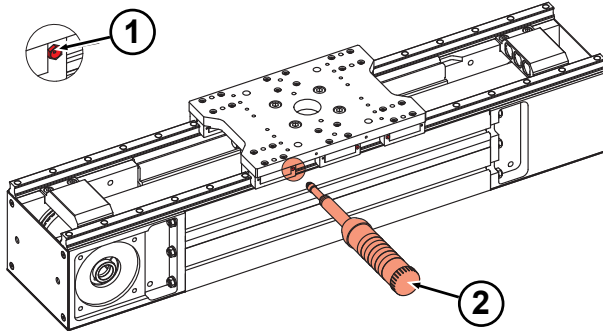

1 Funnel-type lubricating nipple
DIN 3405

2 Recommended grease gun:
ZPE.FETTPRESSE.03
(without attachment 01.528)

DM2/DM3.ZR...A... with 4 carriages

Each of the 4 individual lubrication points (A, C, D, F) must be lubricated.

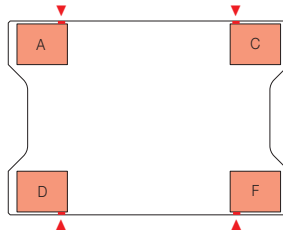

DM2/DM3.ZR...D... with 6 carriages

Each of the 6 individual lubrication points (A...F) must be lubricated.

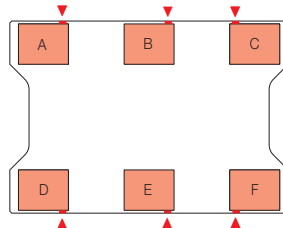

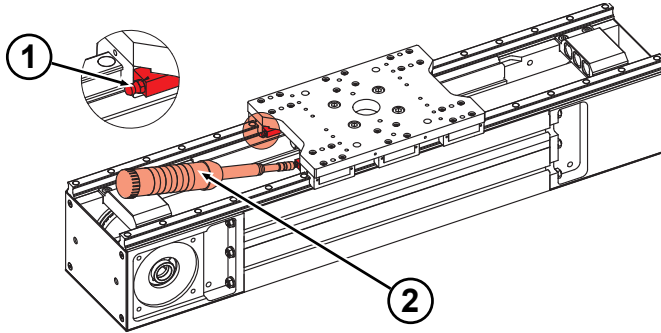
Central lubrication: with lubricating strips

1 Lubrication nipple M6
(DIN 71412 A)

2 Recommended grease gun:
ZPE.FETTPRESSE.03
(with attachment 01.528)

DM2/DM3.ZR...B/C... with central lubrication on motor side/side opposite the motor

The two central lubrication points 1 (A + C) and 2 (D + F) must be lubricated.

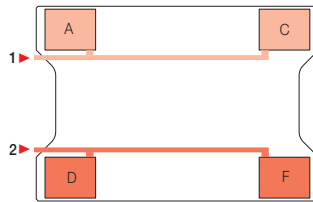
**DM2/DM3.ZR...E/F... with central lubrication on motor side/side opposite the motor**

The two central lubrication points 1 (A + B + C) and 2 (D + E + F) must be lubricated.

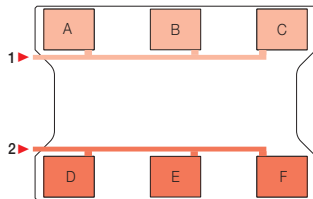

7.4.3 Tensioning the toothed belt

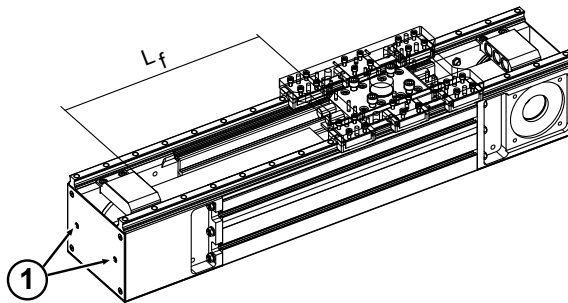

1 Tensioning screws

Tension the toothed belt as follows:

- Position the carriage according to L_f in relation to the deflection housing.
- Position the belt in the center of the drive pulley and idler pulley.
- Tighten the tensioning screws evenly (alternately left/right).
- Measure the belt frequency in the center L_f and across the entire belt width.
- Readjust until the setpoint frequency is achieved everywhere.
- Move the carriage back and forth.
- Readjust until the belt runs in the middle of the pulleys.
- Check the belt frequency.

	L_f [mm]	f_{set} [Hz]	Allen screw [mm]
DM2.ZR...	400	85 ± 5	6
DM3.ZR...	600	50 ± 5	8

7.5 Measures after completing the maintenance work

After completing the maintenance work and before switching the system on, carry out the following steps:

- a) Check that all previously loosened screw connections are tight.
- b) Check that all previously removed protective devices and covers have been properly reinstalled. Clean the work area and remove any substances that may have leaked, e.g., liquids, processing material or similar.
- c) Make sure that all tools, materials and other equipment that were used have been removed from the work area.
- d) Make sure that all safety equipment is in perfect working order.



DANGER

Danger to life due to premature reactivation!

There is a risk of injury to personnel located in or reaching into the danger zone if the device is switched on again.

- ▶ Before switching the system back on, make sure that there are no personnel in the danger zone or reaching into the danger zone.

8 Faults

8.1 Safety



SAFETY INSTRUCTIONS

Working safely during troubleshooting!

Carry out all work in compliance with the following safety instructions:

- ▶ Comply with the provisions listed in the *Safety* [▶ 14] chapter for all work performed on/with the dynamic module.
- ▶ All troubleshooting work must only be carried out by specially trained personnel (see the *Personnel requirements* [▶ 16] chapter).
- ▶ Work on electrical systems must only be carried out by qualified personnel (see the *Qualifications* [▶ 16] chapter).
- ▶ Wear protective equipment in accordance with local accident prevention regulations for all troubleshooting work.
- ▶ Before starting work, switch off the electrical supply and secure it against being switched on again.
- ▶ Make sure that there is sufficient space for assembly before starting work.
- ▶ Make sure that the assembly area is tidy and clean! Loose components and tools lying on top of each other or lying around may cause accidents.
- ▶ If components have been removed or adjusted, ensure correct assembly, reinstall all fastening elements and observe the screw tightening torques.
- ▶ Observe environmental protection instructions.

8.2 What to do in case of faults that pose a danger

The following generally applies:

- In case of faults that pose an immediate danger to personnel or property, switch off the machine immediately.
- Determine the cause of the fault and notify the person responsible at the operating site of the fault.
- If it is necessary to enter danger zones or reach into danger zones during troubleshooting work, secure the machine against being switched on again.
- Have the fault repaired by authorized specialist personnel.

8.3 Possible faults

Possible faults can be indicated by the following:

- Unusual noises
- Sluggish running
- Inaccuracies



NOTE

Contact LINE TECH AG service for troubleshooting (See reverse side) .

8.4 Measures after completing the troubleshooting work

After completing the troubleshooting work and before switching the machine back on, implement the following measures:

- a) Tighten all previously loosened screw connections.
- b) Make sure that previously removed protective devices and covers are properly reinstalled.
- c) Make sure that all tools and work materials have been removed from the work area.
- d) Clean the work area and remove any substances that may have leaked, such as liquids, processing material or similar, and dispose of them in an environmentally friendly manner.
- e) Make sure that all safety equipment is properly installed and functional.



DANGER

Danger to life due to premature reactivation!

There is a risk of injury to personnel located in or reaching into the danger zone if the device is switched on again.

- ▶ Before switching the system back on, make sure that there are no personnel in the danger zone or reaching into the danger zone.

9 Disassembly and disposal

9.1 Safety



SAFETY INSTRUCTIONS

Working safely when disassembling and disposing of the machine!

Carry out all work in compliance with the following safety instructions:

- ▶ Comply with the provisions listed in the *Safety* [▶ 14]chapter for all work performed on/with the dynamic module.
- ▶ The disassembly work must only be carried out by specially trained personnel (see the *Personnel requirements* [▶ 16] chapter).
- ▶ Work on electrical systems must only be carried out by qualified electricians (see the *Qualifications* [▶ 16] chapter).
- ▶ Wear protective equipment in accordance with local accident prevention regulations for all disassembly and disposal work.
- ▶ Before starting disassembly, switch off the electrical supply and permanently disconnect it.
- ▶ Make sure there is sufficient space before starting work.
- ▶ Make sure that the work area is tidy and clean. Loose components and tools lying on top of each other or lying around may cause accidents. Be careful when handling exposed components that have sharp edges.
- ▶ Disassemble components correctly. Note the high dead weight of some components. Use lifting equipment if necessary. Secure components so that they do not fall or fall over.
- ▶ Incorrect handling of environmentally hazardous substances, especially incorrect disposal, can cause considerable damage to the environment. If environmentally hazardous substances are accidentally released into the environment, immediately take measures and notify the responsible local authority of the damage.

9.2 Decommissioning and disassembly

To decommission the dynamic module:

- a) Switch off the power supply to the entire system and disconnect it from the power supply.
- b) If necessary, disconnect the pneumatic connections.

- c) Disassemble the dynamic module.
- d) Store the dynamic module (see the *Storage* [▶ 26] chapter) or
- e) disassemble the dynamic module into assemblies in compliance with the applicable local environmental protection regulations.

9.3 Disposal



NOTICE

Environmental damage due to incorrect disposal!

Lubricants and other auxiliary materials are subject to hazardous waste treatment and must only be disposed of by authorized specialist companies! Have disassembled components recycled:

- ▶ Scrap metals.
- ▶ Have plastic elements recycled.
- ▶ Sort the remaining components according to their material properties and dispose of them separately. The local authorities or specialist disposal companies can provide information regarding environmentally friendly disposal.

Pretreat and dispose of the components according to the following table:

Components	Pretreatment	Disposal
Mechanical components	Clean	Scrap
Greases	Remove, clean	See the safety data sheet
Oils	Drain, pump out	See the safety data sheet

10 Technical data

10.1 Exploded drawing and parts list

Standard version

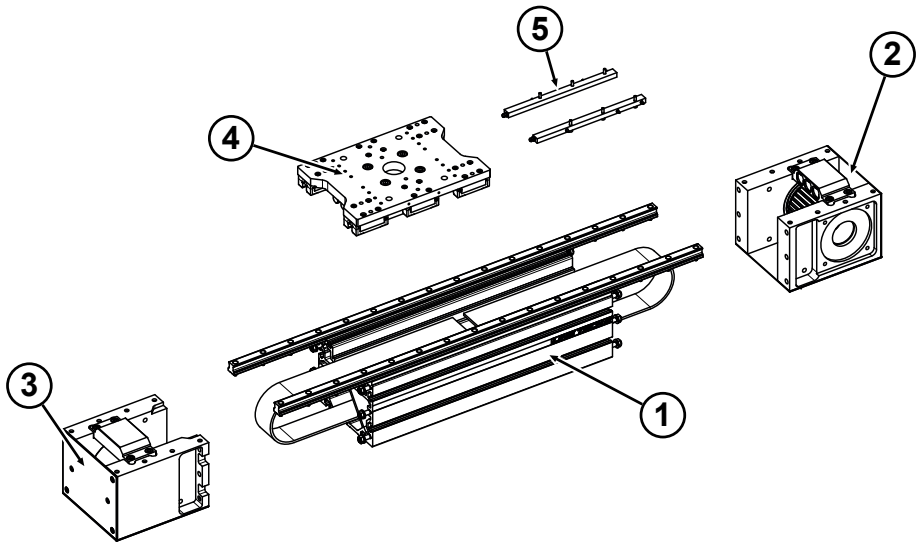

- 1 Basic structure
- 3 Deflection housing
- 5 Central lubrication

- 2 Drive housing
- 4 Carriage

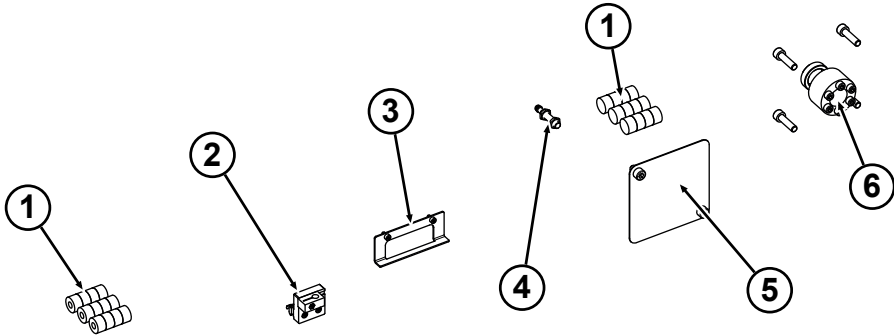
Accessories/options

- 1 PU high-performance buffer
- 3 Switching lug
- 5 Cover plate

- 2 Sensor holder
- 4 Limit switch cable
- 6 Gearbox mounting kit

10.2 General technical data

DM	Toothed belt drive		Axial load	Positioning accuracy	Repeatability	Acceleration
Size	Stroke/U [mm]	Elongation ³⁾ [mm/m]	F [N]	[μm]	.../1000 mm [mm]	a _{max} [m/s ²]
DM2.ZR...	320	0.037	1)	200/1000 ²⁾	± 0.05 ²⁾	50.0 ⁴⁾
DM3.ZR...	392	0.023	1)	200/1000 ²⁾	± 0.05 ²⁾	50.0 ⁴⁾

1) Depending on speed and load

2) Without consideration of the play and load

3) Belt elongation/meter [mm/m] per 100 N tensile force

4) Maximum possible value; effective value to be determined on an application-specific basis with our Technical Sales department

DM	Travel speed		Moments of inertia		Max. stroke	Feed and frictional force	Moving mass/ carriages
Type	Linear guide v _{max} [m/min]	Drive v _{max} [m/min]	I _y [cm ⁴]	I _z [cm ⁴]	[mm]	F _v [N]	m _b [kg]
DM2.ZR...A/B/C... ⁸⁾	360 ⁷⁾	5)	1780	3184	5880 ⁶⁾	65	6.4
DM2.ZR...D/E/F... ⁸⁾	360 ⁷⁾	5)	1780	3184	5880 ⁶⁾	80	7.2
DM3.ZR...A/B/C... ⁸⁾	360 ⁷⁾	5)	5183	8917	5770 ⁶⁾	80	12.3
DM3.ZR...D/E/F... ⁸⁾	360 ⁷⁾	5)	5183	8917	5770 ⁶⁾	100	13.7

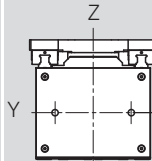

5) Depending on the load and speed as well as the permissible travel speed of the linear guide, according to catalog

6) Larger strokes according to catalog

7) Higher speeds according to catalog

8) ...A/B/C... = 4 Carriage / ...D/E/F... = 6 carriages

Carriage plate dimensions DM2.ZR...

DM2.ZR...A/B/C... with 4 carriages

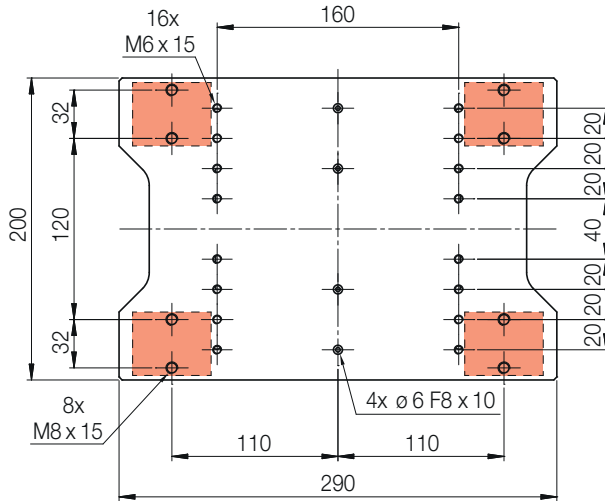

DM2.ZR...D/E/F... with 6 carriages

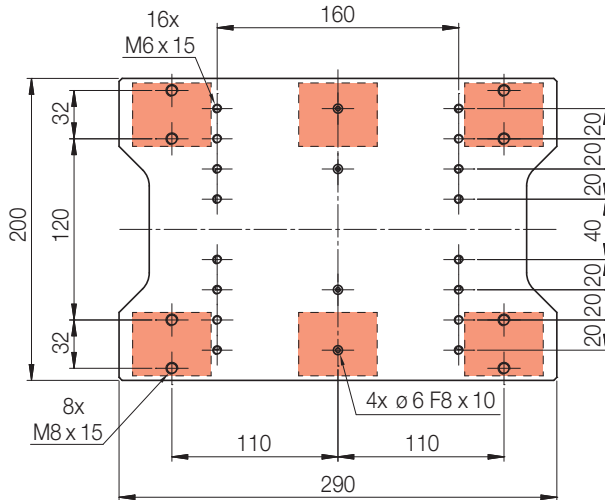

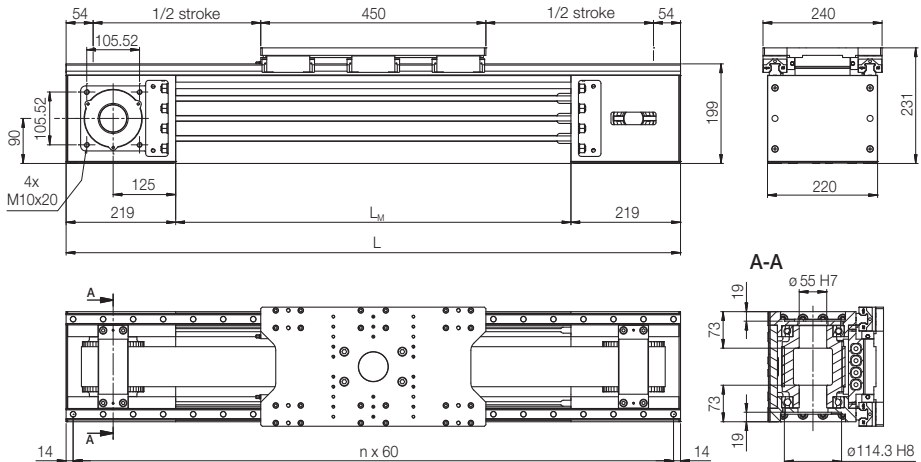
Dynamic module DM3.ZR

Nominal size	Dimensions			Weight (excluding gearbox)
	Designation	L [mm]	L_M [mm]	
DM3.ZR...A/B/C...	Stroke* + 558	$L - 438$	2 x stroke + 1124	55.1 kg + 4.63 kg/100 mm stroke
DM3.ZR...D/E/F...	Stroke* + 558	$L - 438$	2 x stroke + 1124	56.5 kg + 4.63 kg/100 mm stroke

^{*)} Be sure to note that the stroke can only be selected in the following increments:

Stroke = 10 + n x 60

Example: stroke = 430 mm / 490 mm / 550 mm / ... all 60 mm ... / 5650 mm / 5710 mm / 5770 mm

Carriage plate dimensions DM3.ZR...

DM3.ZR...A/B/C... with 4 carriages

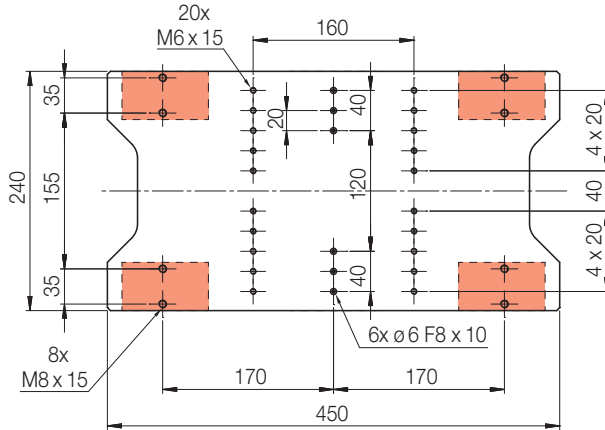

DM3.ZR...D/E/F... with 6 carriages

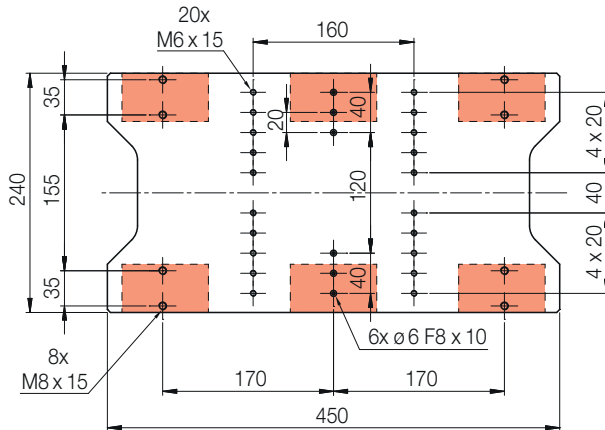

10.4 Torques and load ratings

Tragzahlen

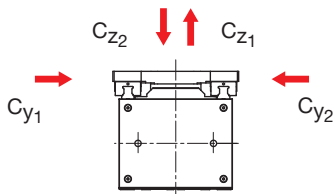

Momente

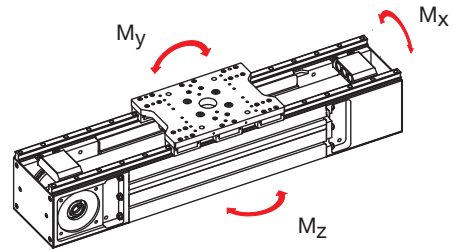

Dynamic module Type	Maximum permissible forces [kN]				Maximum permissible torques [Nm]					
	Static		Dynamic		Static			Dynamic		
	$C_{y_{0.1.2}}$	$C_{z_{0.1.2}}$	$C_{y_{1.2.50}}$	$C_{z_{1.2.50}}$	M_{x_0}	M_{y_0}	M_{z_0}	$M_{x_{50}}$	$M_{y_{50}}$	$M_{z_{50}}$
DM2.ZR... A/B/C... ¹⁾	108	108	77.5	77.5	8,200	11,880	11,880	5,900	8,530	8,530
DM2.ZR... D/E/F... ¹⁾	162.0	162.0	116.3	116.3	12,310	12,080	12,080	8,840	8,790	8,790
DM3.ZR... A/B/C... ¹⁾	207.7	207.7	139.2	139.2	19,730	35,310	35,310	13,220	23,670	23,670
DM3.ZR... D/E/F... ¹⁾	311.5	311.5	208.8	208.8	29 600	35 950	35 950	19 840	24 470	24 470

¹⁾ ...A/B/C... = 4 Carriage / ...D/E/F... = 6 carriages



NOTE

The determination of the basic dynamic load ratings and torques is based on a stroke of 50 km. If comparative values need to be calculated for a stroke of 100 km, divide the values for $M_{x_{50}}$, $M_{y_{50}}$, $M_{z_{50}}$ and C_{50} by a factor of 1.26.

10.5 Permissible speeds

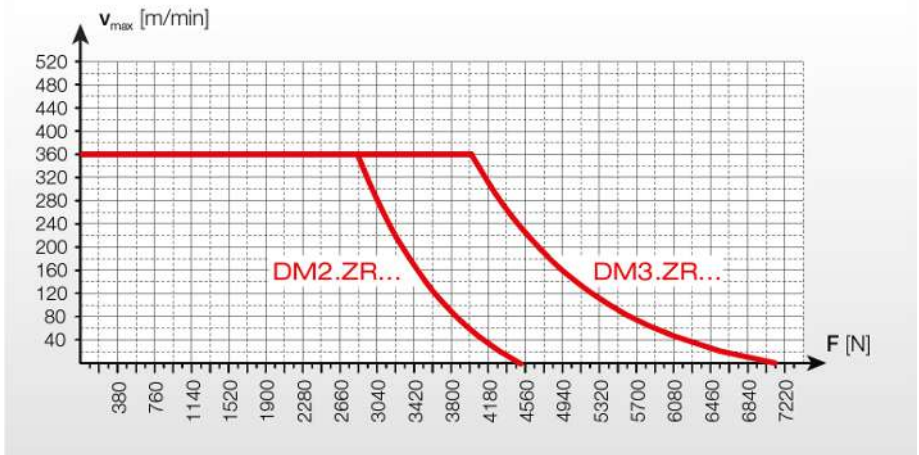

F = Axial load

10.6 Tightening torques for screws

Screws of strength class 8.8 are used as standard. If other screws are used, they are specially marked. The tightening torques recommended by LINE TECH AG are defined in the following table.

Tightening torques $M_{A,max.}$ [Nm]					Friction factor for screws $\mu = 0.120$					
Screw acc. to	Material class	Thread size								
		M2	M2.5	M3	M4	M5	M6	M8	M10	M12
ISO 4762 (DIN 912)	8.8	0.36	0.73	1.27	3.00	5.90	10.10	24.60	48.00	84.00
ISO 4762 (DIN 912)	12.9	0.60	1.23	2.14	5.10	10.00	17.40	42.20	83.00	144.00
ISO 47380	10.9	0.25	0.50	0.90	2.00	4.00	7.20	12.00	23.00	58.00

11 Declaration of Incorporation

Declaration of Incorporation

according to EC Machinery Directive 2006/42/EC, Annex II 1. B

(Translation of original Declaration of Incorporation)

Manufacturer

Line Tech AG

Europastrasse 19
CH-8152 Glattbrugg

Module name

Dynamic module (DM)

Type designation

according to type plate (see *Type plate* [▶ 22])

Serial number

according to type plate (see *Type plate* [▶ 22])

Manufacturing date

according to type plate (see *Type plate* [▶ 22])

We hereby declare that

the product specified below complies with the essential safety requirements of the Machinery Directive, including the amendments applicable at the time of the declaration, to the extent permitted by the scope of delivery, due to its design, construction and type in the version that we have launched on the market.

The following essential safety requirements of the Machinery Directive have been satisfied:

- 1.1.2 Principles for the integration of safety
- 1.1.3 Materials and products
- 1.1.5 Design of the machine for handling
- 1.3.2 Risk of breakage during operation
- 1.3.3 Risks due to falling or ejected objects
- 1.3.4 Risks due to surfaces, edges and corners
- 1.3.7 Risks due to moving parts
- 1.3.9 Risk of uncontrolled movements
- 1.5.2 Static electricity
- 1.5.4 Assembly errors
- 1.5.5 Extreme temperature
- 1.5.6 Fire
- 1.5.8 Noise
- 1.5.13 Emission of hazardous materials and substances
- 1.6.1 Maintenance of the partly completed machinery
- 1.7.2 Warning of residual risks

The product is a partly completed machine as defined by the Machinery Directive. The product is solely intended for installation in a complete system.

Relevant EU directives

EC Directive as amended 2006/42/EC - Machinery Directive

Applied harmonized standards

The machine complies with the safety requirements of the following harmonized standards:

DIN EN ISO 12100:03/2011: Safety of machinery - General principles for design - Risk assessment and risk reduction

Technical documentation

The specific technical documentation in accordance with Annex VII, Part B has been compiled. The representative responsible for compiling the technical documentation undertakes to submit the documentation to the national authorities upon justified request. The documentation shall be submitted by post in paper form or on an electronic data carrier.

Documentation Officer

Line Tech AG, Europastrasse 19, CH-8152 Glattbrugg

Commissioning

The product may not be commissioned until it has been established that the machine in which the aforementioned product is installed complies with all the essential requirements of the Machinery Directive.



Daniel Rees
(Head of Technology/Design)

LINE TECH AG
Europastrasse 19
CH-8152 Glattbrugg

Glattbrugg, April 2025

Index

A

Accidents	13
Assembly type	28

C

Clamps	31
Contact points	28

D

Danger level	
Danger to life	7
Personal injury	8
Property damage	8
Risk of injury	8
Danger zones	16
Decommissioning	51
Disclaimer	11
Disposal	52
Documents; other applicable	13

E

Environment	19
Environmental protection	19, 52

F

F/C ratio	44
Faults	13
Forklift truck	24

G

Greases	19
---------	----

H

Hearing protection	17, 19
--------------------	--------

I

Instructions	15
Intended use	14
Item to be transported	24

L

Limit switches	34
Load ratings	21
Lubricants	19

M

Maintenance plan	41
Mandatory reading	5
Manufacturer	16

N

Noise level	19
Note on useful information	9
Note on working safely	9

O

Obligations	10
Oils	19
Operating site	18
Operation	38
Original spare parts	12

P

Personal protective equipment	15
personnel	
Instructed	16
Unauthorized	16
Personnel requirements	16
Product description	21
Protective equipment	16
Protective goggles	17

Q

Qualification	16
Qualified personnel	16

R

Reference switch	34
Repairs	41
Requirements	5

S

Safety	15
Safety gloves	17
Safety shoes	17
Service center	16
Sliding blocks	33
Sources of information; other	13
Spare parts	12
Specialist personnel	16
Storage	26
Storage location	5

T

Technical changes	10
Type plate	22

W

Warning symbols	9
Electric current	9
Environmental pollution	9
Suspended load	9
Warranty claims	12
Warranty conditions	12
Work clothing	17
Work clothing; appropriate	17

LINE TECH

Linear movements form the backbone of modern industrial production systems. LINE TECH AG has been providing linear technology solutions every day for over 25 years. LINE TECH AG is distinguished by a comprehensive range of components, linear and positioning systems coupled with the technical expertise of our employees.



Advanced services ranging from engineering to design, combined with flexible production, round off the product range and provide you, the customer, with a wide range of advantages.



Proprietary products

LINE TECH's proprietary products include modular, ready-to-install linear axes:

- Linear modules
- Bridge modules
- Compact units
- Positioning units



Systems / assemblies

Our engineering department develops customized solutions at the customer's request.



Components

Commercial products supplement the range, including linear guides, drives, and components:

- Linear guides
- Toothed belt drives
- Roller linear guides
- Ball bushings and shafts
- Ball rollers
- Comprehensive range of accessories
- Megatorque motors
- Linear motors

LINE TECH AG
Europastrasse 19
CH-8152 Glattbrugg
Switzerland

Telephone +41 (0) 43 211 68 68
Fax +41 (0) 43 211 68 69
info@linetech.ch

Revisionsstand:
4/2/2026

