

≡ Bridge module BM4...NZ...N XL with toothed belt drive

BM	Toothed belt drive				Axial load F [N]	Positioning accuracy [μ/mm]	Repeating accuracy .../1000 mm [mm]	Acceleration a_{max} [m/s ²]
	Type/division	Pinion $d_3 \times l_p$ [mm]	Stroke/rev [mm]	Tension ³⁾ [mm/m]				
BM4...Z...	HTD5M	65.25 x 45	205	0.105	... ¹⁾	200/1000 ²⁾	< 0.20 ²⁾	50.0 ¹⁾

$d_3 \times l_p$ = pinion diameter x pinion width

¹⁾ depending on speed and load

²⁾ backlash not factored in

³⁾ belt tension/metre [mm/m] per 100 N tensile force

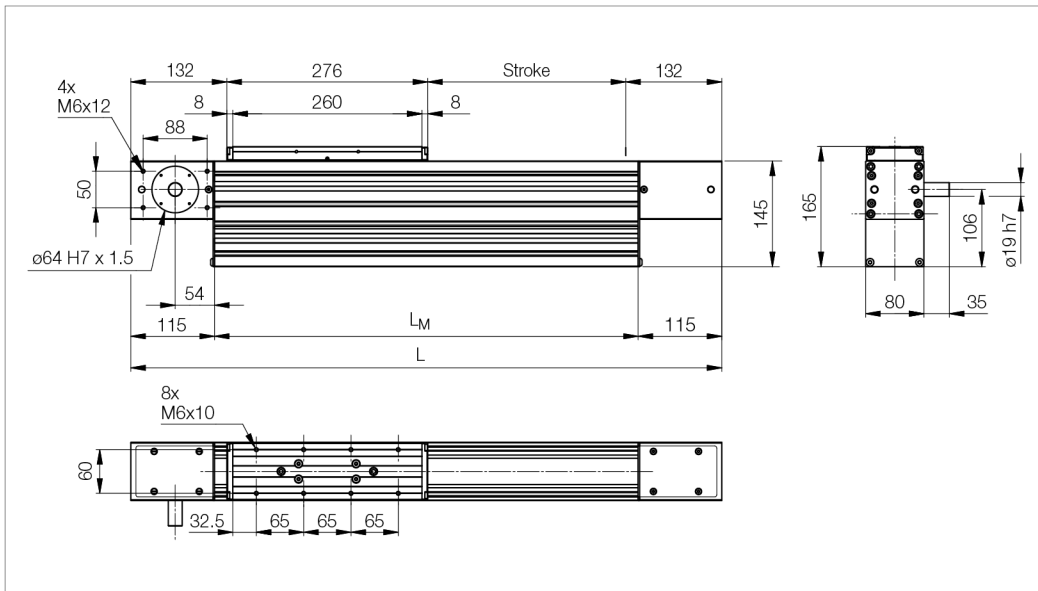

Nominal size	Dimensions			
Designation	L [mm]	L_M [mm]	Belt length [mm]	Weight [kg]
BM4...NZ...N	Stroke + 540	L - 230	2 x Stroke + 900	9.70 kg + 1.36 kg/100 mm Stroke

Variants/dimensions with protective strip (BM4...BZ...N) see catalogue

BM	Movement speed		Moments of inertia		Stroke max. [mm]	Steel strip	Feed and friction force F_V [N]	Moved mass m_b [kg]
	Guide v_{max} [m/s]	Drive v_{max} [m/s]	I_y [cm ⁴]	I_z [cm ⁴]				
BM4...Z...N	5.0	⁴⁾	708	332	XL: 12 480	without with	25.00 35.00	2.150 2.170

⁴⁾ for toothed belt drive, dependent on load and speed and permissible movement speed of the linear guide

Bridge module Type	Maximum permissible load [kN]				Maximum permissible torque [Nm]					
	static		dynamic		static			dynamic		
	$C_{y0,1,2}$	$C_{z0,1,2}$	$C_{y1,2}$	$C_{z1,2}$	M_{x0}	M_{y0}	M_{z0}	M_x	M_y	M_z
BM4...Z...N	59.9	59.9	34.2	34.2	646	1573	1573	400	1446	1446

The determination of dynamic load ratings and torques is based on a 50,000 m stroke. If comparative values must be calculated for a 100,000 m stroke, the values for M_x , M_y , M_z and C must be divided by the factor 1.26.

With a view to serviceable life, loads of less than 20% of the dynamic load ratings have generally proved to be expedient.

XL Please contact LINE TECH for Consulting & Engineering →

Enquiry (technical/quote)

Download data sheet (PDF)

Download catalogue (PDF)